

Schematic:

| REV. | ECN NO. | DESCRIPTION | DATE | APPD |
|------|---------|-------------|------------|------|
| A | REL | | 2015-04-22 | |

PCB SIDE TO PHY

CABLE SIDE

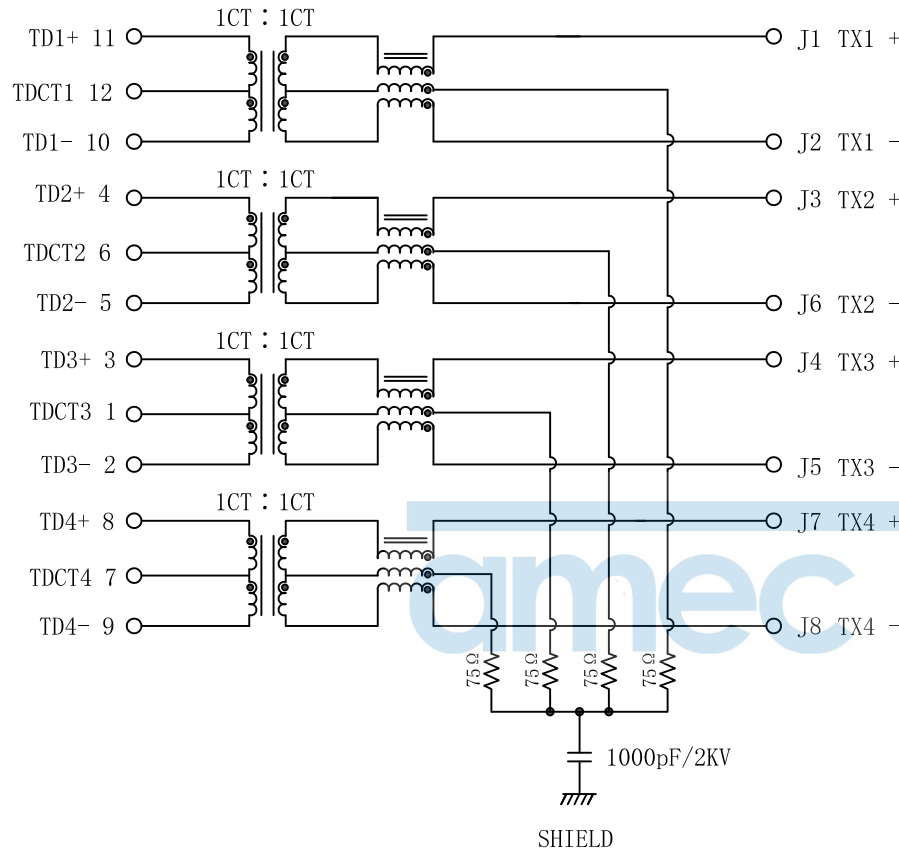

ELECTRICAL SPECIFICATIONS @25°C

- Turn Ratio($\pm 3\%$):
Pri:Sec = 1CT:1CT
- Inductance OCL:
350uH MIN @ 100KHz 0.1V 8mA DC Bias
- DCR: 1.2 Ω MAX
- Insertion Loss:
-1.0dB MAX @ 1-100MHz
- Return Loss:
-18dB MIN @ 1-30MHz
-15dB MIN @ 30-60MHz
-12dB MIN @ 60-100MHz
- Cross talk:
-40dB MIN @ 1-30MHz
-35dB MIN @ 30-60MHz
-30dB MIN @ 60-100MHz
- Common Mode Rejection:
-30dB MIN @ 1-50MHz
-20dB MIN @ 50-150MHz
- Hipot Test: 1500Vrms
- Operating Temperature Range: 0°C TO 70°C



Langer Acker 32
30900 Wedemark
Germany

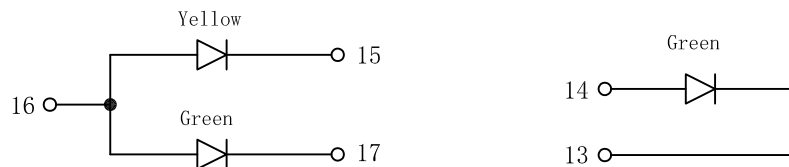

Left LED

Right LED

| Emitting Color | λ p(nm) | V _F @I _F =20mA | I _R @V _R =5V |
|----------------|-----------------|--------------------------------------|------------------------------------|
| Green | 565 | 1.8~2.4V | 10 μ A max |
| Yellow | 585 | 1.8~2.4V | 10 μ A max |

| | | | | |
|--------|---------------|------------|---|----------------------|
| X:X | ± 0.25 | APPD: | Trxcom Huizhou Trxcom Electronics Co., Ltd. | |
| X:XX | ± 0.20 | CHKD: | | |
| X:XXX | ± 0.05 | DR: SEA | TITLE: RJ45 Connector with 1000 Base-T Integrated Magnetics | |
| ANGLES | $\pm 1^\circ$ | UNIT: mm | PART NO.: TRJK7003A97NL | |
| | SCALE: 2/1 | SHEET: 2/4 | REV: A | DWG NO.: TRC14011021 |

Profile of wave solder:

| REV. | ECN NO. | DESCRIPTION | DATE | APPD |
|------|---------|-------------|------------|------|
| A | REL | | 2015-04-22 | |

SUGGESTED PROFILE OF WAVE SOLDER FOR ROHS PRODUCT

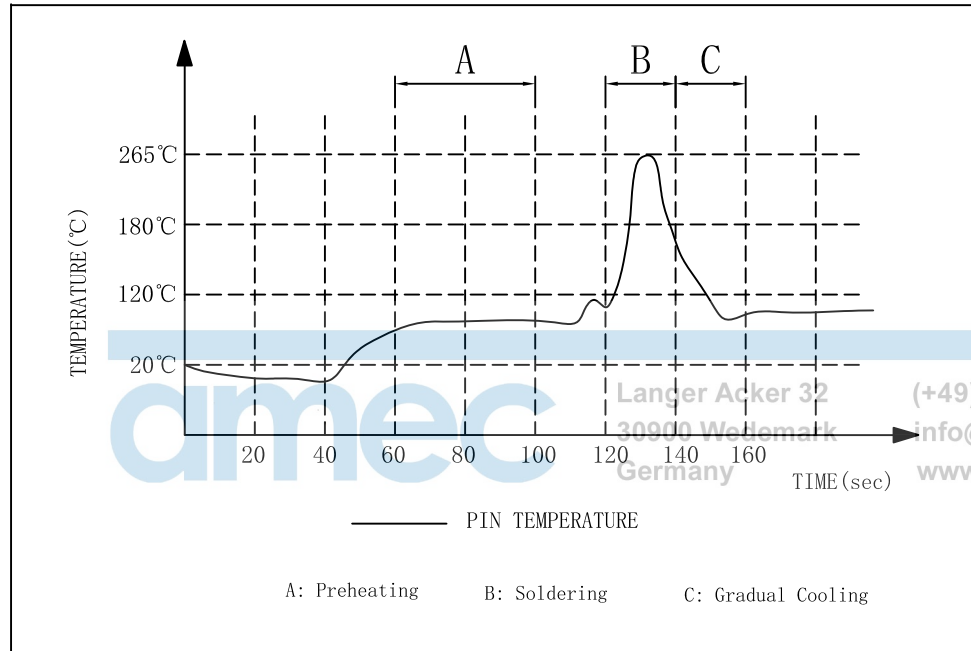

- (1) Tip Temperature: 265°C max
 - (2) Tip Temperature time: 5sec max
- Note: The melting point of Tin: 219°C

| | | |
|-------------|------------|---|
| X:X ±0.25 | APPD: | Trxcom |
| X:XX ±0.20 | CHKD: | |
| X:XXX ±0.05 | DR: SEA | TITLE: RJ45 Connector with 1000 Base-T Integrated Magnetics |
| ANGLES ±1° | UNIT: mm | PART NO.: TRJK7003A97NL |
| | SCALE: 2/1 | SHEET: 3/4 |
| | REV: A | DWG NO.: TRC14011021 |

Packaging:

| REV. | ECN NO. | DESCRIPTION | DATE | APPD |
|------|---------|-------------|------------|------|
| A | REL | | 2015-04-22 | |

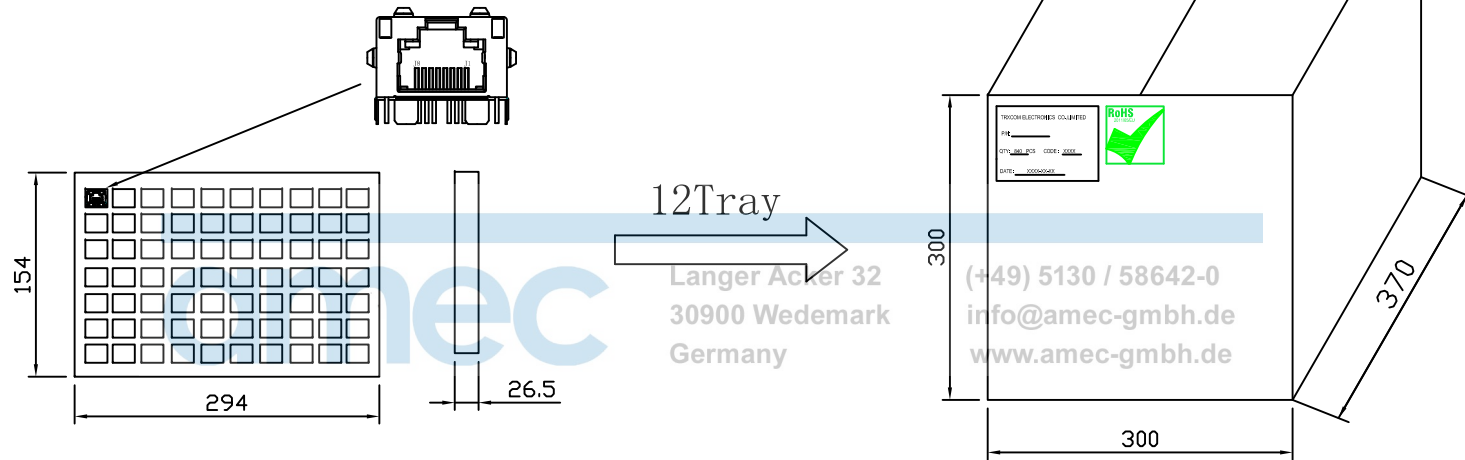

- ◆ Packaging unit :70pcs/tray
- ◆ Packaging material:PVC
- ◆ Outer carton unit:840pcs/12tray/box
- ◆ Net Weight:8kg
- ◆ Gross Weight:10kg

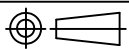
| | | | |
|---|-------|----------------------|--|
| X:X | ±0.25 | APPD: | Trxcom Huizhou Trxcom Electronics Co.,Ltd. |
| X:XX | ±0.20 | CHKD: | |
| X:XXX | ±0.05 | DR: SEA | |
| ANGLES | ±1° | UNIT: mm | TITLE: 1*1 24.14 RJ45 PACKING |
|  | | | PART NO.: TRJK7003A97NL |
| SCALE: | 2/1 | SHEET: 4/4 | REV: A |
| | | DWG NO.: TRC14011021 | |