

Schematic:

REV.	ECN NO.	DESCRIPTION	DATE	APPD
A	REL		2010-08-20	

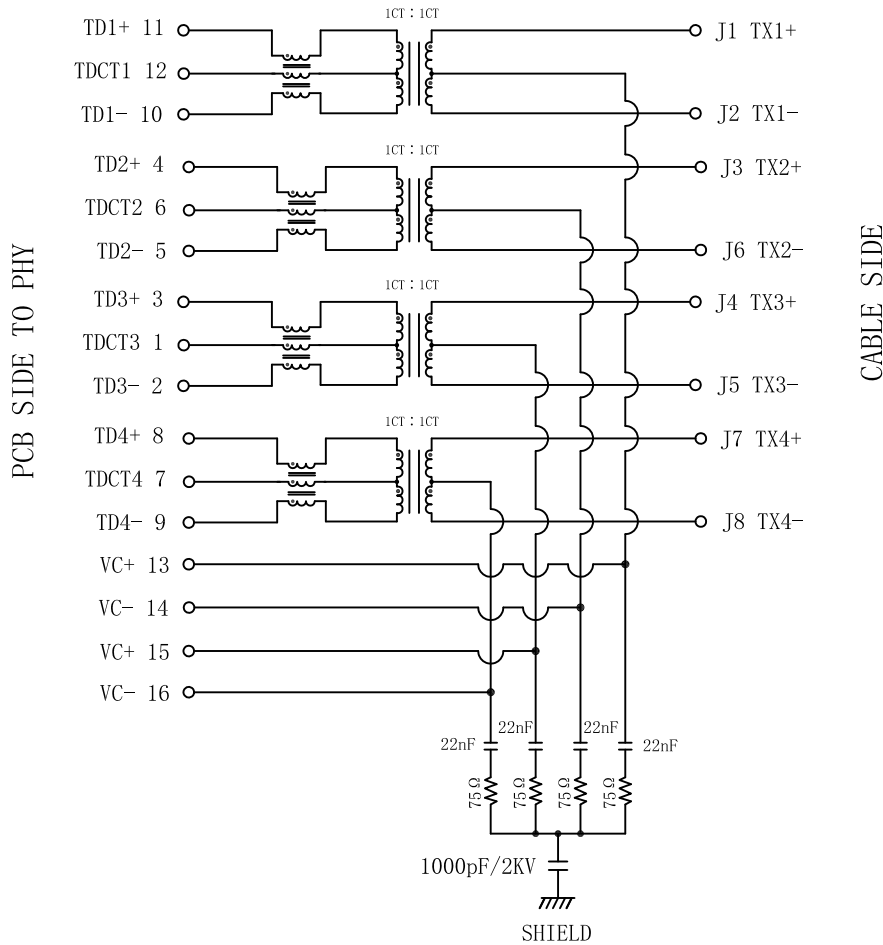

Electrical Specifications @25°C

- Inductance: 350uH Min @ 100KHz, 0.1V, 8mA DC BIAS
- Turns Ratio($\pm 2\%$): Pri : Sec = 1CT : 1CT
- Insertion Loss: 1-100MHz: -1.0dB Max
- Return Loss(load 100 Ω): 1-30MHz: -18dB Min
30-60MHz: -16dB Min
60-80MHz: -12dB Min
80-100MHz: -10dB Min
- Crosstalk: 1-100MHz: -30dB Min
- Common Mode Rejection: 1-100MHz: -30dB Min
- Hipot: 1500Vrms Min @60Hz
- 15W, 350mA, 48V PoE rating.
- Operating Temperature: 0°C ~ 70°C.

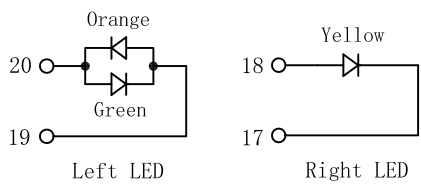
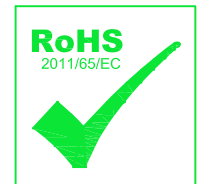

Emitting Color	λ p(nm)	VF@IF=20mA	IR @VR=5V
Green	565	1.8~2.4V	10 μ A max
Yellow	585	1.8~2.4V	10 μ A max
Orange	610	1.8~2.4V	10 μ A max

X:X	± 0.25	APPD:	Trxcom Huizhou Trxcom Electronics Co., Ltd.	
X:XX	± 0.20	CHKD:		
X:XXX	± 0.05	DR: SEA	TITLE: RJ45 Connector with 1000 Base-T Integrated Magnetics For PoE Application	
ANGLES	$\pm 1^\circ$	UNIT: mm	PART NO. : TRJK2064AONL	
	SCALE: 2/1	SHEET: 2/4	REV: A	DWG NO. : TRC10082005

Profile of wave solder:

REV.	ECN NO.	DESCRIPTION	DATE	APPD
A	REL		2010-08-20	

SUGGESTED PROFILE OF WAVE SOLDER FOR ROHS PRODUCT

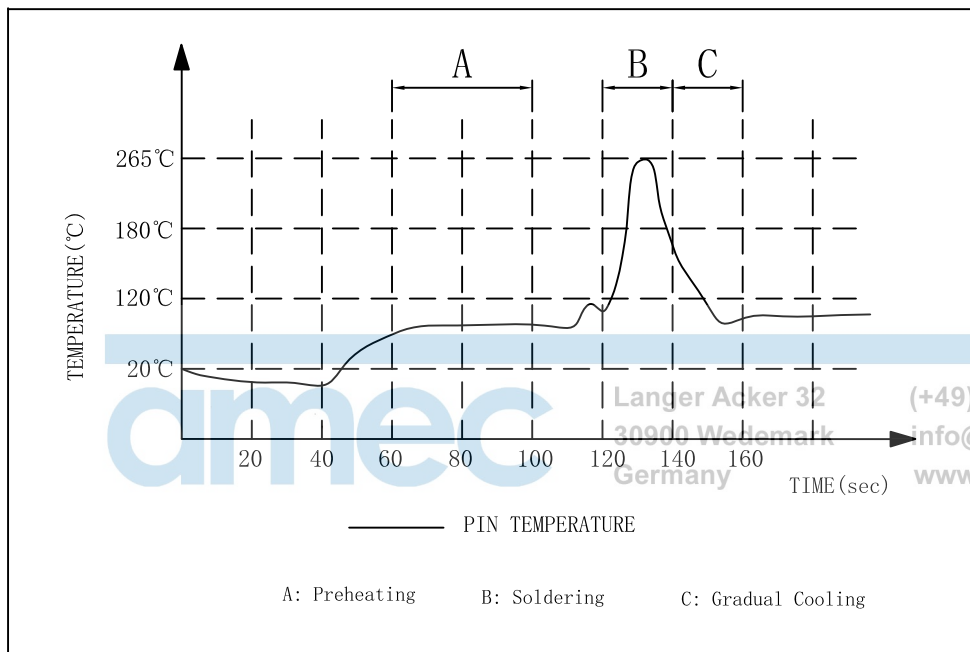

Langer Adker 32 (+49) 5130 / 58642-0
 30900 Wellemark info@amec-gmbh.de
 Germany www.amec-gmbh.de



- (1) Tip Temperature: 265°C max
 - (2) Tip Temperature time: 5sec max
- Note: The melting point of Tin: 219°C

X:X ±0.25	APPD:	Trxcom Huizhou Trxcom Electronics Co., Ltd.
X:XX ±0.20	CHKD:	
X:XXX ±0.05	DR: SEA	
ANGLES ±1°	UNIT: mm	TITLE: RJ45 Connector with 1000 Base-T Integrated Magnetics For PoE Application
		PART NO. : TRJK2064AONL
	SCALE: 2/1	SHEET: 2/4
	REV: A	DWG NO. : TRC10082005

Packaging:

REV.	ECN NO.	DESCRIPTION	DATE	APPD
A	REL		2010-08-20	

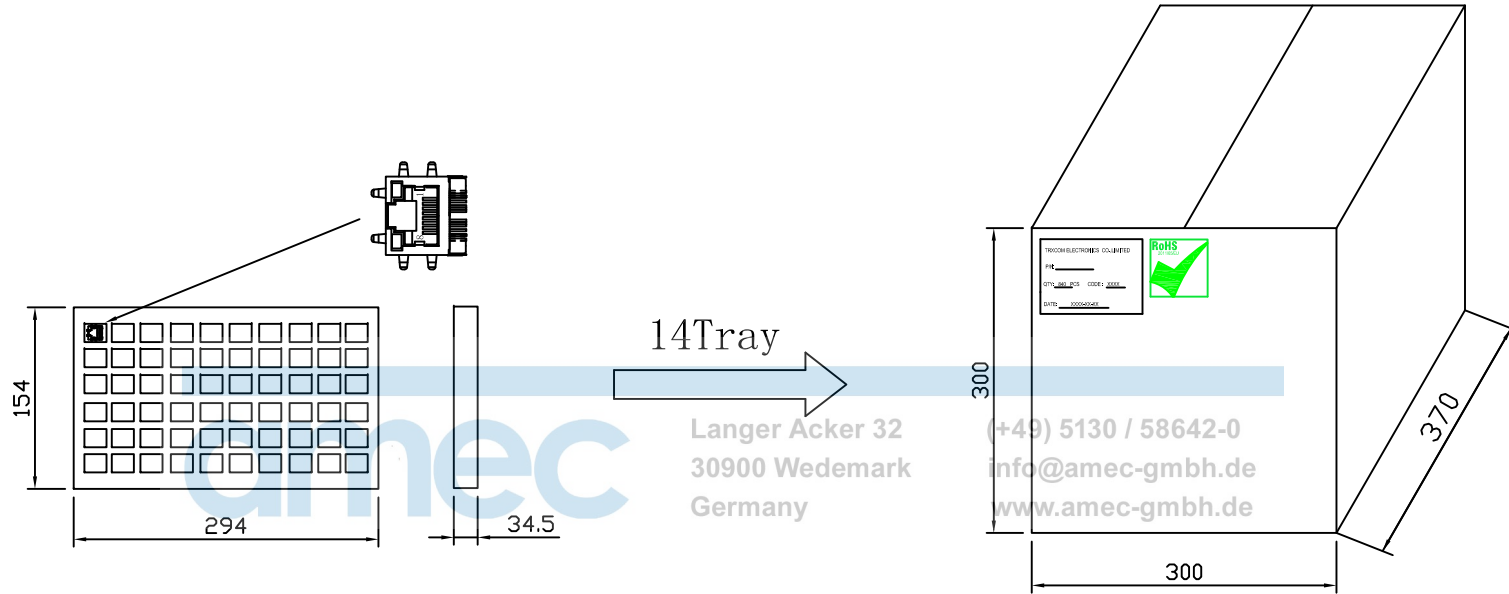

- ◆ Packaging unit :60pcs/tray
- ◆ Packaging material:PVC
- ◆ Outer carton unit:840pcs/14tray/box
- ◆ Net Weight:7kg
- ◆ Gross Weight:9kg

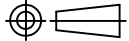
X:X	±0.25	APPD:	Trxcom Huizhou Trxcom Electronics Co.,Ltd.
X:XX	±0.20	CHKD:	
X:XXX	±0.05	DR: SEA	
ANGLES	±1°	UNIT: mm	TITLE: 1*1 33.02 RJ45 PACKING
			PART NO. : TRJK2064AONL
SCALE:	2/1	SHEET: 4/4	REV: A
		DWG NO. :	TRC10082005