

Schematic:

REV.	ECN NO.	DESCRIPTION	DATE	APPD
A	REL		2015-04-18	

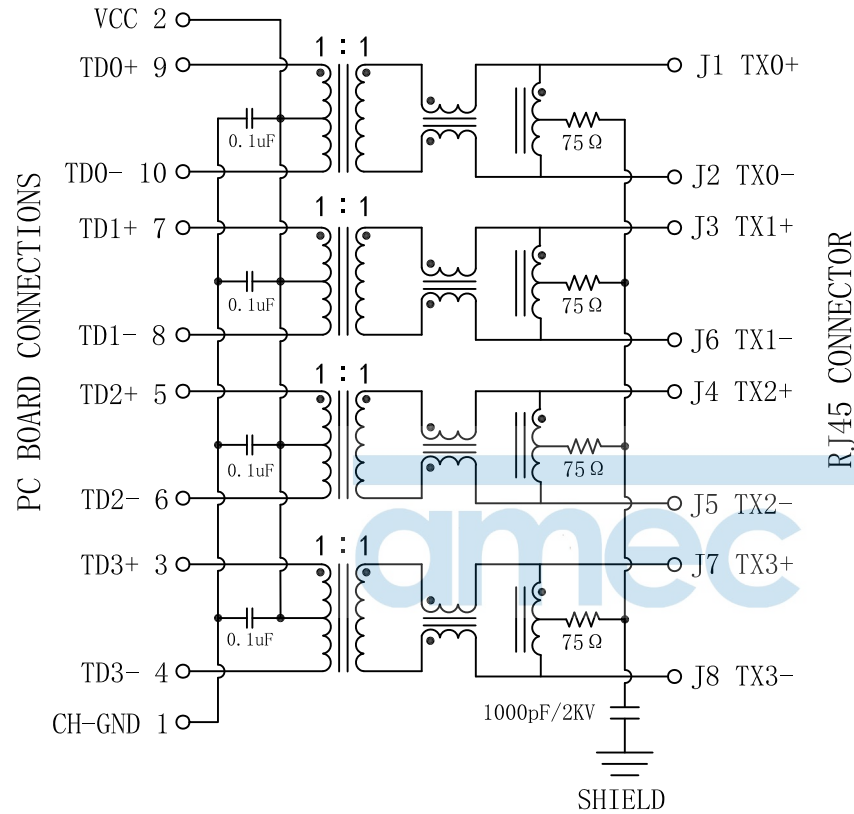

RJ45 CONNECTOR

Langer Acker 32
30900 Wedemark
Germany

ELECTRICAL SPECIFICATIONS @25°C

- Turn Ratio ($\pm 3\%$):
TX=1CT:1CT RX=1CT:1CT
- Inductance OCL:
350uH MIN @100KHz 0.1V 8mA DC Bias
- DCR:
1.2 Ω MAX
- Insertion Loss:
-1.1dB MAX @1-100MHz
- Return Loss:
-16dB MIN @1-30MHz
-12dB MIN @30-60MHz
-10dB MIN @60-100MHz
- Cross talk:
-40dB MIN @1-30MHz
-35dB MIN @30-60MHz
-30dB MIN @60-100MHz
- Common Mode Rejection:
-30dB MIN @1-50MHz
-20dB MIN @50-150MHz
- Hipot Test: 1500Vrms.
- Operating Temperature Range: 0°C TO 70°C.



X:X	± 0.25	APPD:	Trxcom Huizhou Trxcom Electronics Co., Ltd.	
X:XX	± 0.20	CHKD:		
X:XXX	± 0.05	DR: SEA	TITLE: RJ45 Connector with 1000 Base-T Integrated Magnetics	
ANGLES	$\pm 1^\circ$	UNIT: mm	PART NO.: TRJG16314CNL	
	SCALE: 2/1	SHEET: 2/4	REV: A	DWG NO.: TRC15041818

REV.	ECN NO.	DESCRIPTION	DATE	APPD
A	REL		2015-04-18	

SUGGESTED PROFILE OF WAVE SOLDER FOR ROHS PRODUCT

REV: A
 TEMP(°C): 25
 HUM(%): 65 RH

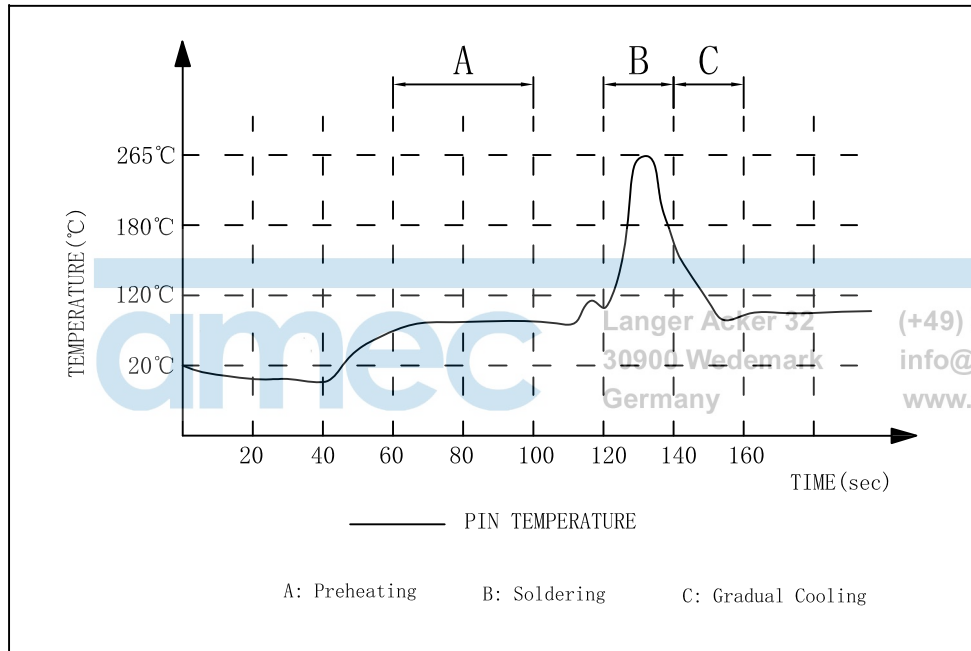

- (1) Tip Temperature: 265°C max
 - (2) Tip Temperature time: 5sec max
- Note: The melting point of Tin: 219°C

X:X ±0.25	APPD:	Trxcom
X:XX ±0.20	CHKD:	
X:XXX ±0.05	DR: SEA	TITLE: RJ45 Connector with 1000 Base-T Integrated Magnetics
ANGLES ±1°	UNIT: mm	PART NO.: TRJG16314CNL
	SCALE: 2/1	SHEET: 3/4
	REV: A	DWG NO.: TRC15041818

Packaging:

REV.	ECN NO.	DESCRIPTION	DATE	APPD.
A	REL		2015-04-18	

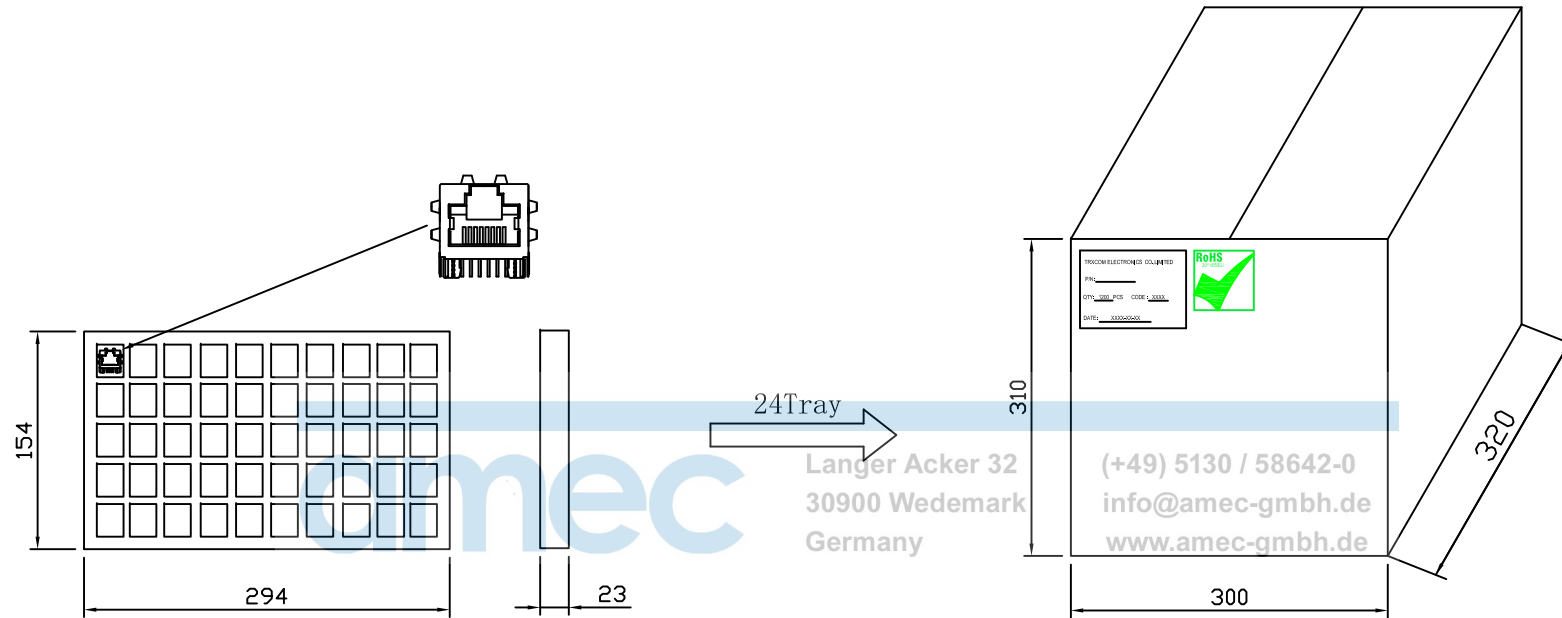

- ◆ Packaging unit :50pcs/tray
- ◆ Packaging material:PVC
- ◆ Outer carton unit:1200pcs/24tray/box
- ◆ Net Weight:8kg
- ◆ Gross Weight:10kg

X:X	±0.25	APPD:	Trxcom Huizhou Trxcom Electronics Co.,Ltd.	
X:XX	±0.20	CHKD:		
X:XXX	±0.05	DR: SEA	TITLE: 1*1 21.3 RJ45 PACKING	
ANGLES	±1°	UNIT: mm	PART NO.: TRJG16314CNL	
	SCALE: 2/1	SHEET: 4/4	REV: A	DWG NO.: TRC15041818