

Schematic:

REV.	ECN NO.	DESCRIPTION	DATE	APPD
A	REL		2015-05-30	

PC BOARD CONNECTIONS

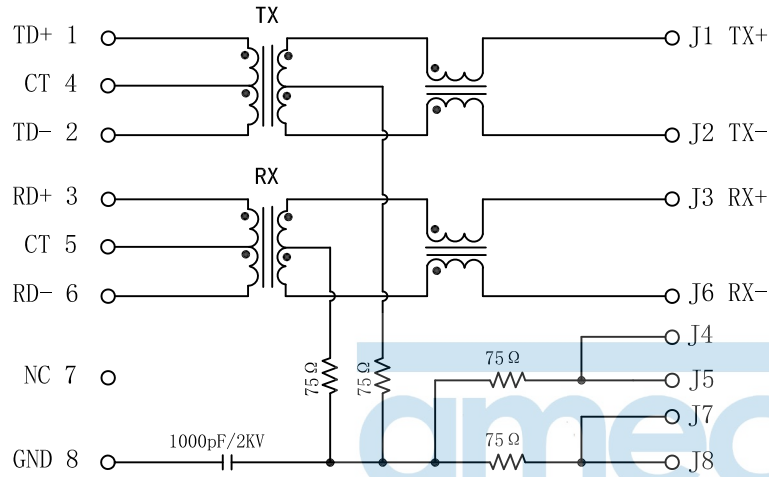

Electrical Specification @25°C

- Turns Ratio ($\pm 2\%$):
TX=1CT:1CT RX=1CT:1CT
- OCL: 350uH Min
@100KHz, 100mV, 8mA bias current
- Insertion Loss(dB Max):
1-80MHz:-1.0 100MHz:-1.2
- Return Loss(dB Min):
1-60MHz:-14 60-100MHz:-10
- Crosstalk:
1-80MHz:-35dB Min
- Isolation Voltage: 1500Vrms
- Operating Temperature: 0°C~70°C.

Langer Acker 32
30900 Wedemark
Germany



X:X	± 0.25	APPD:	Trxcom Huizhou Trxcom Electronics Co., Ltd.	
X:XX	± 0.20	CHKD:		
X:XXX	± 0.05	DR: SEA	TITLE: Surface Mount 1×1 Tab-Up Jack With 10/100 Magnetic	
ANGLES	$\pm 1^\circ$	UNIT: mm	PART NO.: TRJ19211DNL	
	SCALE: 2/1	SHEET: 2/4	REV: A	DWG NO.: TRC13122644

REV.	ECN NO.	DESCRIPTION	DATE	APPD
A	REL		2015-05-30	

SUGGESTED PROFILE OF WAVE SOLDER FOR ROHS PRODUCT

REV: A
 TEMP(°C): 25
 HUM(%): 65 RH

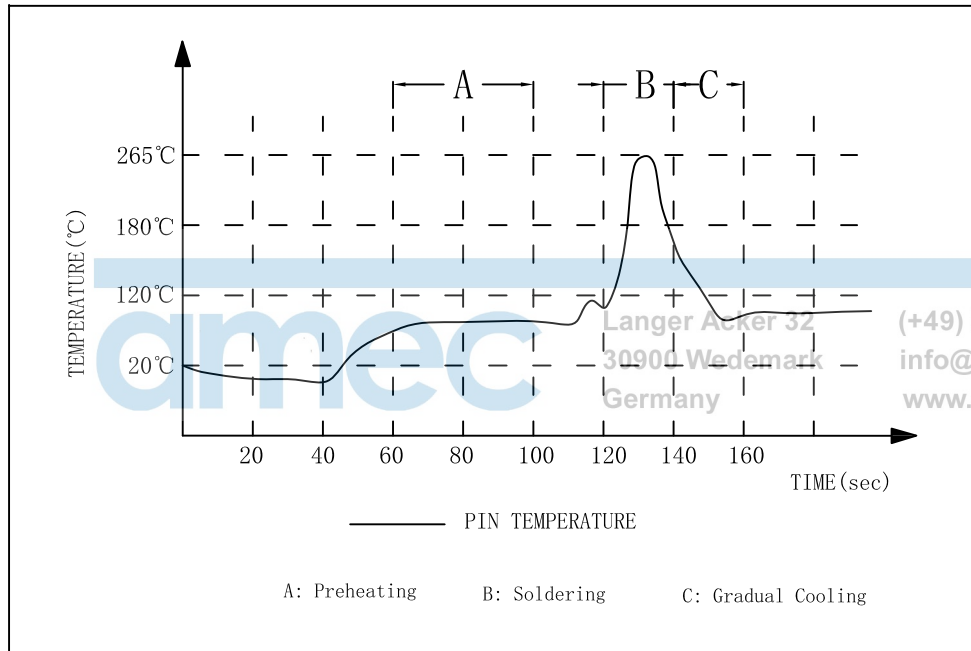

- (1) Tip Temperature: 265°C max
 - (2) Tip Temperature time: 5sec max
- Note: The melting point of Tin: 219°C

X:X ±0.25	APPD:	Trxcom
X:XX ±0.20	CHKD:	
X:XXX ±0.05	DR: SEA	TITLE: Surface Mount 1×1 Tab-Up Jack With 10/100 Magnetic
ANGLES ±1°	UNIT: mm	PART NO.: TRJ19211DNL
	SCALE: 2/1	SHEET: 2/4
	REV: A	DWG NO.: TRC13122644

Packing:

REV.	ECN NO.	DESCRIPTION	DATE	APPD
B	REL		2015-05-30	

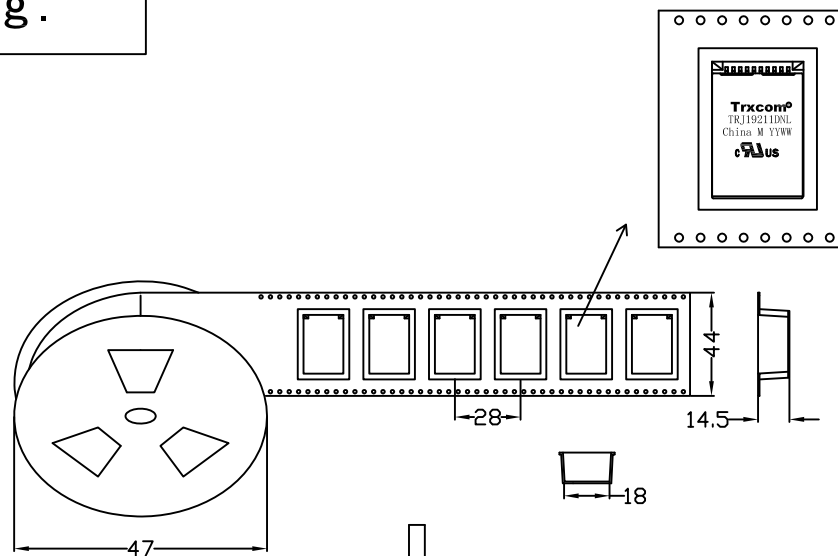

150/Reel

1 Reel

PE BAG

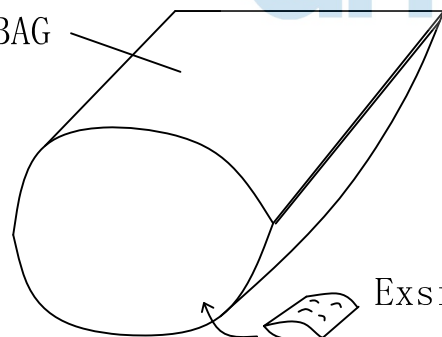

Exsiccaters

amec

Langer Acker 32
30900 Wedemark
Germany

6 Bag

(+49) 5130 1586 40
info@amec-gmbh.de
www.amec-gmbh.de

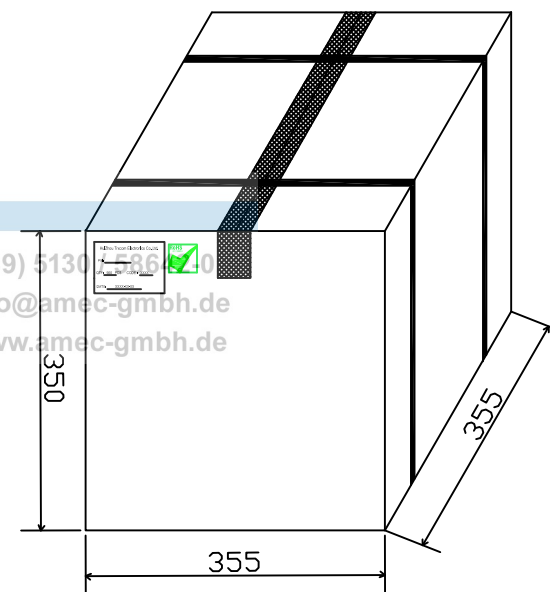

- ◆ Packaging unit : 150 pcs/ reel
- ◆ Packaging way : Carrier tape
- ◆ Outer carton unit : 900 pcs/ 6 Reel/ box
- ◆ Net Weight : 6.5 kg
- ◆ Gross Weight : 9 kg

X:X	±0.25	APPD:	Trxcom Huizhou Trxcom Electronics Co.,Ltd.	
X:XX	±0.20	CHKD:		
X:XXX	±0.05	DR: SEA	TITLE: Surface Mount 1×1 Tab-Up Jack With 10/100 Magnetic	
ANGLES	±1°	UNIT: mm	PART NO. : TRJ19211DNL	
	SCALE: 2/1	SHEET: 4/4	REV: A	DWG NO. : TRC13122644