

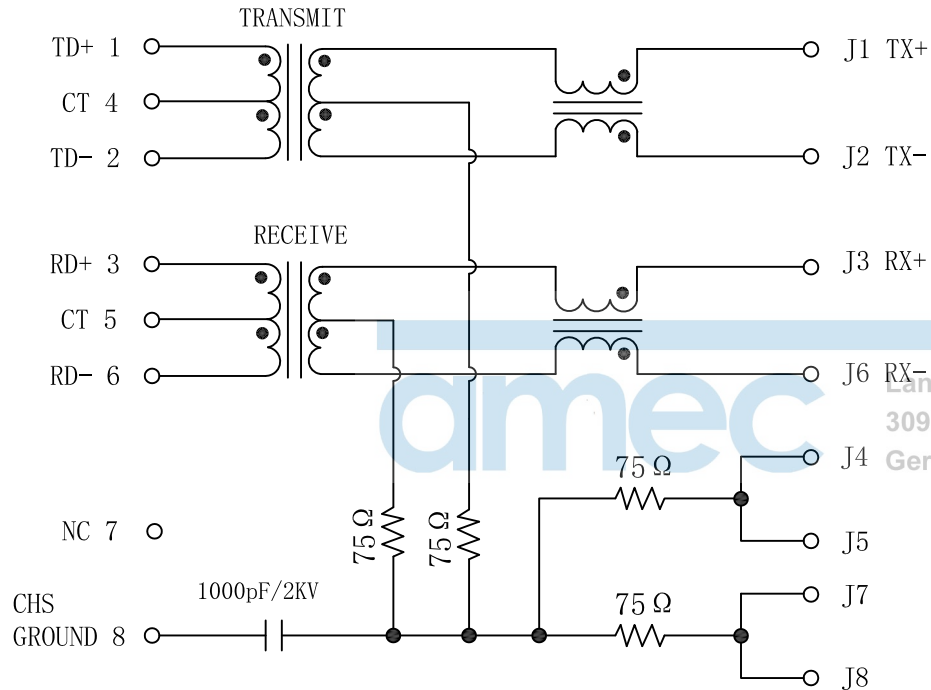

Schematic:

REV.	ECN NO.	DESCRIPTION	DATE	APPD
A	REL		2015-03-25	

PC BOARD CONNECTIONS



ELECTRICAL SPECIFICATIONS @25°C

- Turn Ratio ( $\pm 3\%$ ):  
TX=1CT:1CT      RX=1CT:1CT
- Inductance OCL:  
350uH MIN @ 100KHz 0.1V 8mA DC Bias
- DCR:  
1.2  $\Omega$  MAX
- Insertion Loss:  
-1.0dB MAX @ 1-100MHz
- Return Loss:  
-18dB MIN @ 1-30MHz  
-15dB MIN @ 30-60MHz  
-12dB MIN @ 60-100MHz
- Cross talk:  
-40dB MIN @ 1-30MHz  
-35dB MIN @ 30-60MHz  
-30dB MIN @ 60-100MHz
- Common Mode Rejection:  
-30dB MIN @ 1-50MHz  
-20dB MIN @ 50-150MHz
- Hipot Test:1500Vrms
- Operating Temperature Range: 0°C TO 70°C



X:X	$\pm 0.25$	APPD:	<b>Trxcom</b> Huizhou Trxcom Electronics Co.,Ltd.	
X:XX	$\pm 0.20$	CHKD:		
X:XXX	$\pm 0.05$	DR: GRANT	TITLE: RJ45 Connector with 10/100 Base-T Integrated Magnetics	
ANGLES	$\pm 1^\circ$	UNIT: mm	PART NO.: TRJ16211CNL	
	SCALE: 2/1	SHEET: 2/4	REV: A	DWG NO.: TRC15032511

REV.	ECN NO.	DESCRIPTION	DATE	APPD
A	REL		2015-03-25	

REV: A  
 TEMP (°C): 25  
 HUM (%): 65 RH

SUGGESTED PROFILE OF WAVE SOLDER FOR ROHS PRODUCT

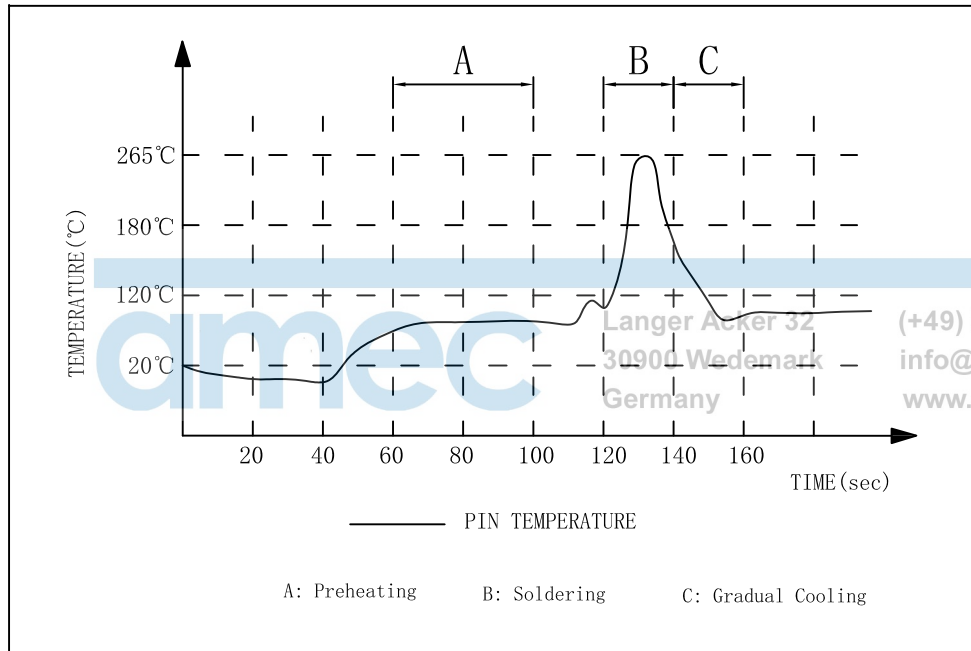

- (1) Tip Temperature: 265°C max
  - (2) Tip Temperature time: 5sec max
- Note: The melting point of Tin: 219°C

X:X ±0.25	APPD:	<b>Trxcom</b>
X:XX ±0.20	CHKD:	
X:XXX ±0.05	DR: GRANT	TITLE: RJ45 Connector with 10/100 Base-T Integrated Magnetics
ANGLES ±1°	UNIT: mm	PART NO.: TRJ16211CNL
	SCALE: 2/1	SHEET: 3/4
	REV: A	DWG NO.: TRC15032511

Packaging:

REV.	ECN NO.	DESCRIPTION	DATE	APPD
A	REL		2015-03-25	

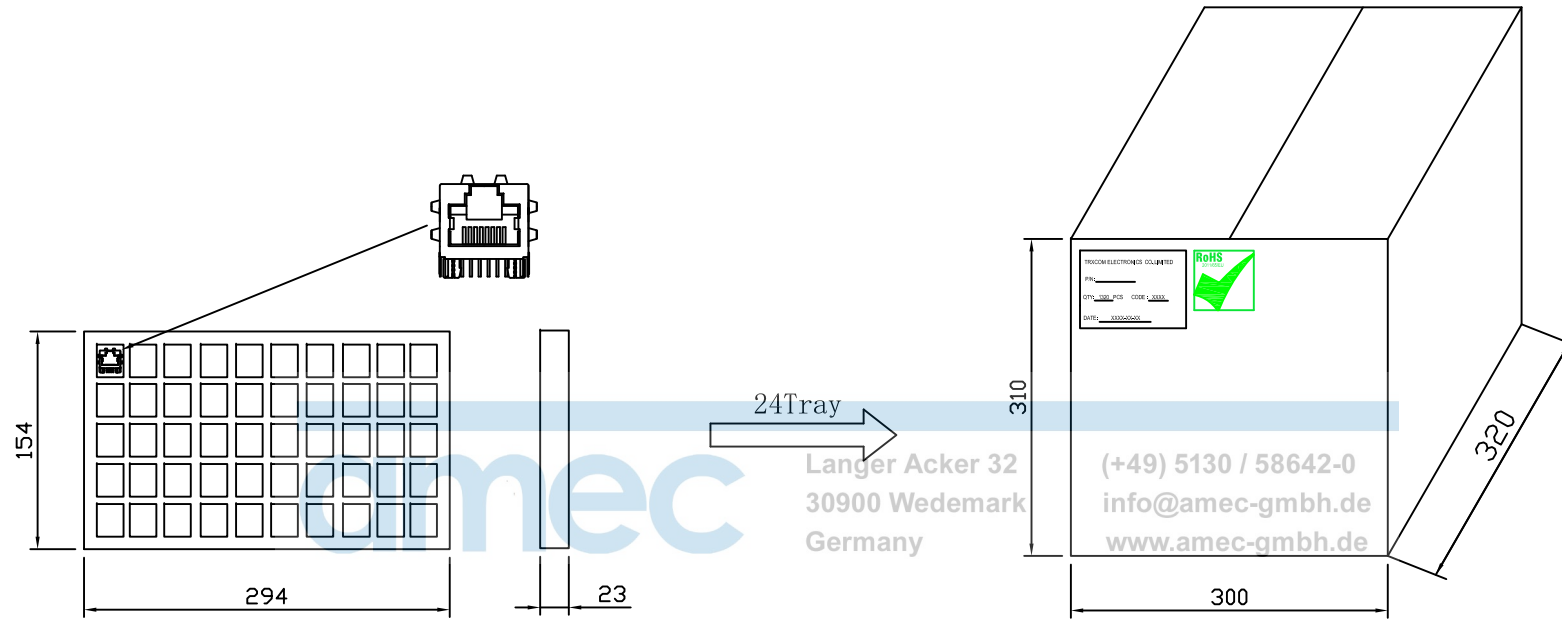

- ◆ Packaging unit :50pcs/tray
- ◆ Packaging material:PVC
- ◆ Outer carton unit:1200pcs/24tray/box
- ◆ Net Weight:8kg
- ◆ Gross Weight:10kg

X:X	±0.25	APPD:	<b>Trxcom</b> Huizhou Trxcom Electronics Co.,Ltd.	
X:XX	±0.20	CHKD:		
X:XXX	±0.05	DR: GRANT	TITLE: 1*1 21.3 RJ45 PACKING	
ANGLES	±1°	UNIT: mm	PART NO. : TRJ16211CNL	
		SCALE: 2/1	SHEET: 1/1	REV: A
				DWG NO. : TRC15032511