

Schematic:

REV.	ECN NO.	DESCRIPTION	DATE	APPD
A	REL		2015-05-08	

PC BOARD CONNECTIONS

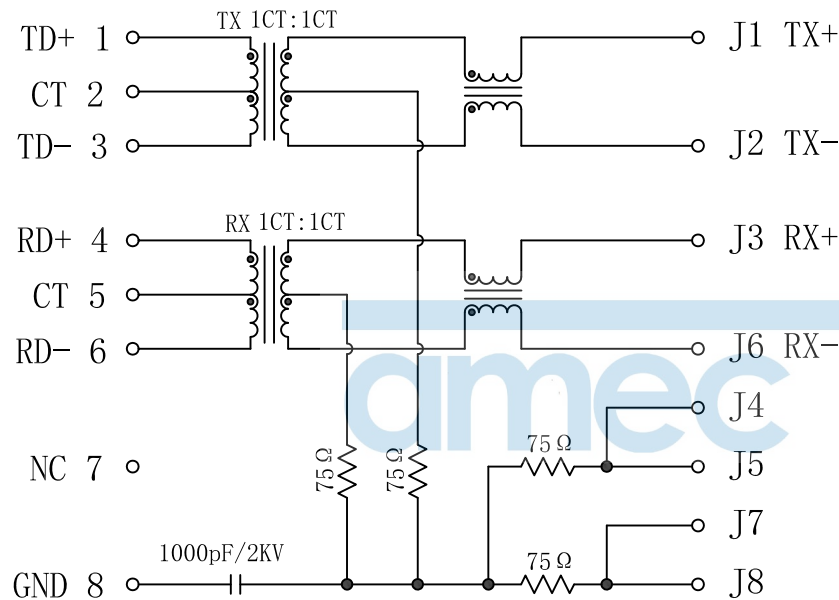

RJ45 CONNECTOR

Langer Acker 32
30900 Wedemark
Germany

ELECTRICAL SPECIFICATIONS @25°C

- Turn Ratio ($\pm 3\%$):
TX=1CT:1CT RX=1CT:1CT
- Inductance OCL:
350uH MIN @ 100KHz 0.1V 8mA DC Bias
- DCR: 1.2 Ω MAX
- Insertion Loss:
-1.0dB MAX @ 1-100MHz
- Return Loss:
-18dB MIN @ 1-30MHz
-15dB MIN @ 30-60MHz
-12dB MIN @ 60-100MHz
- Crosstalk:
-40dB MIN @ 30MHz
-35dB MIN @ 60MHz
-30dB MIN @ 100MHz
- Common Mode Rejection:
-30dB MIN @ 1-100MHz
- Hipot Test: 1500Vrms
- Operating Temperature Range: 0°C TO 70°C



X:X	± 0.25	APPD:	Trxcom	
X:XX	± 0.20	CHKD:	Huizhou Trxcom Electronics Co., Ltd.	
X:XXX	± 0.05	DR: GRANT	TITLE: RJ45 Connector with 10/100 Base-T Integrated Magnetics	
ANGLES	$\pm 1^\circ$	UNIT: mm	PART NO.: TRJ1014CNL	
	SCALE: 2/1	SHEET: 2/2	REV: A	DWG NO.: TRC14070505

Profile of wave solder:

REV.	ECN NO.	DESCRIPTION	DATE	APPD
A	REL		2015-05-08	

SUGGESTED PROFILE OF WAVE SOLDER FOR ROHS PRODUCT

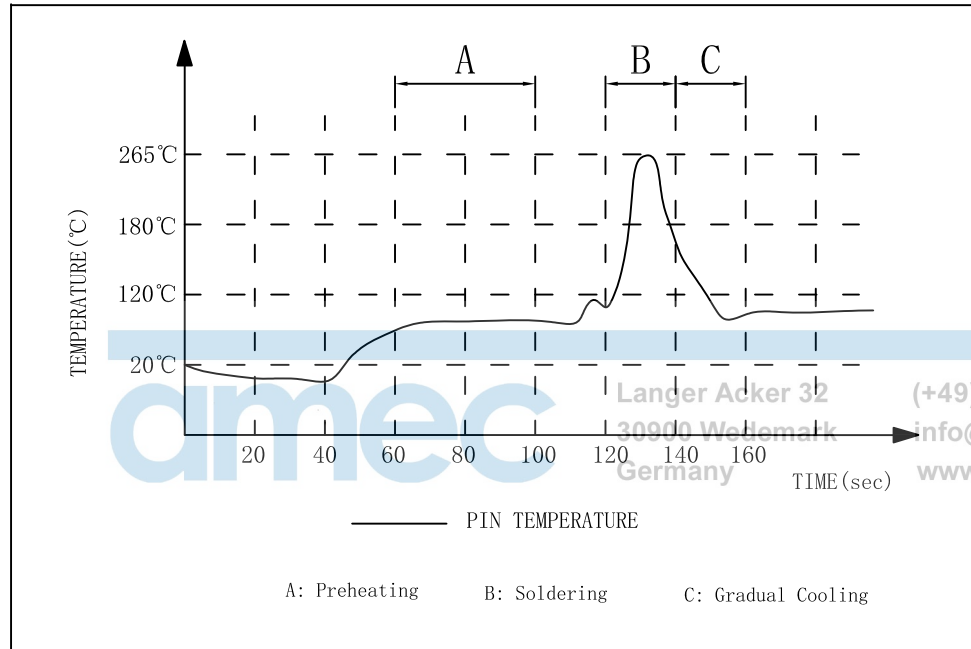

- (1) Tip Temperature: 265°C max
 - (2) Tip Temperature time: 5sec max
- Note: The melting point of Tin: 219°C

X:X ±0.25	APPD:	Trxcom		
X:XX ±0.20	CHKD:	HuiZhou Trxcom Electronics Co., ltd		
X:XXX ±0.05	DR: GRANT	TITLE: RJ45 Connector with 10/100 Base-T Integrated Magnetics		
ANGLES ±1°	UNIT: mm	PART NO.: TRJ1014CNL		
	SCALE: 2/1	SHEET: 3/4	REV: A	DWG NO.: TRC14070505

Packaging:

REV.	ECN NO.	DESCRIPTION	DATE	APPD
A	REL		2015-05-08	

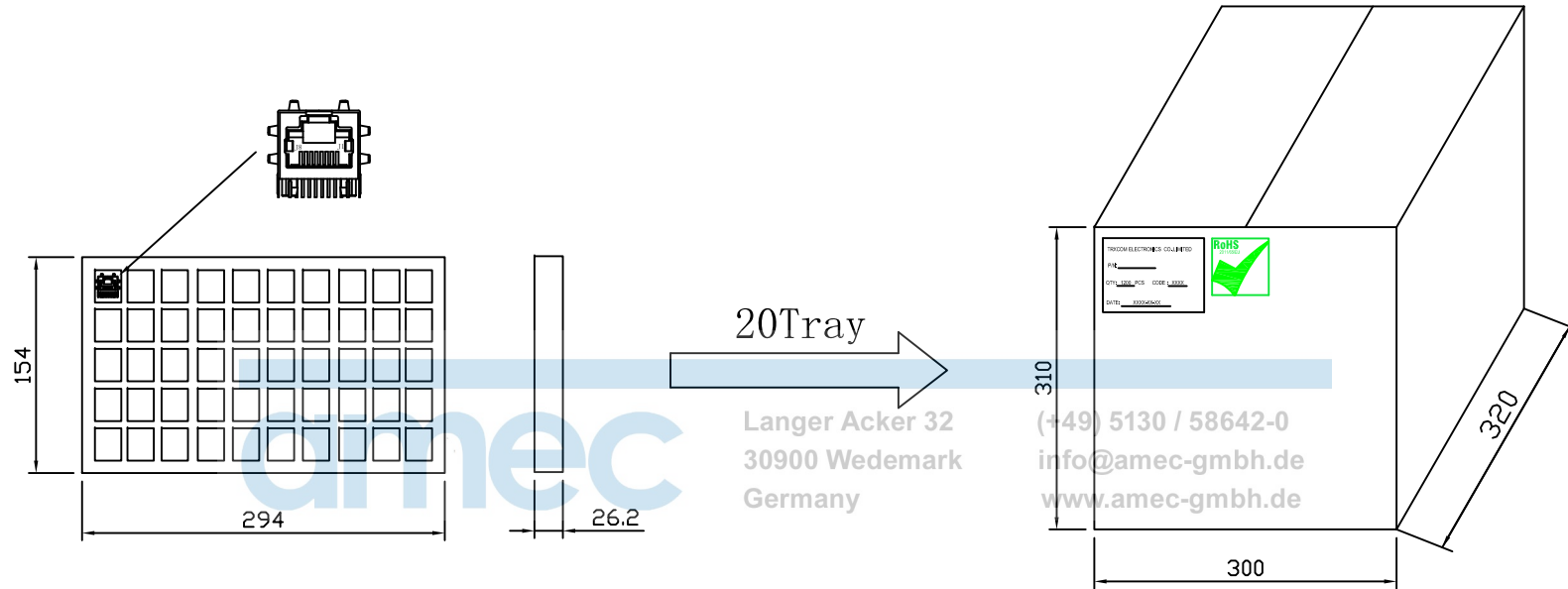

- ◆ Packaging unit :50pcs/tray
- ◆ Packaging material:PVC
- ◆ Outer carton unit:1000pcs/20tray/box
- ◆ Net Weight:7kg
- ◆ Gross Weight:9kg

X:X	±0.25	APPD:	Trxcom Huizhou Trxcom Electronics Co.,Ltd.	
X:XX	±0.20	CHKD:		
X:XXX	±0.05	DR: GRANT	TITLE: 1*1 25.4 RJ45 PACKING	
ANGLES	±1°	UNIT: mm	PART NO. : TRJ1014CNL	
		SCALE: 2/1	SHEET: 4/4	REV: A
				DWG NO. : TRC14070505