

SW Series / Screws for Surface Mount Board

- Can be mounted by automatic mounting machine
- Reflow type
- Projection prevent from slippage
- Useful for board to board connect/board to panel connect
- Can electrify
- Material.....Brass
- Finish.....Plated Sn over Ni base
- Current capacity..... 4SW..... 40A
3SW..... 30A
2.6SW... 20A
2SW..... 10A

- Recommended Land Diameter C ϕ
 - 4SW.....9
 - 3SW.....7
 - 2.6SW...6
 - 2SW.....5
- Recommended Cream Solder Thickness
 - 150~200 μ
 - ※please pour solder into TH hole.
- Tightening Torque
 - 4SW.....6kg·f·cm and below
 - 3SW.....5kg·f·cm and below
 - 2.6SW...4kg·f·cm and below
 - 2SW.....2kg·f·cm and below

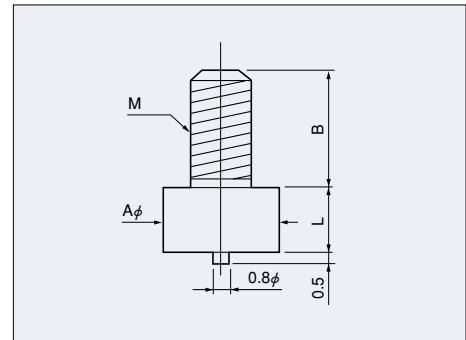
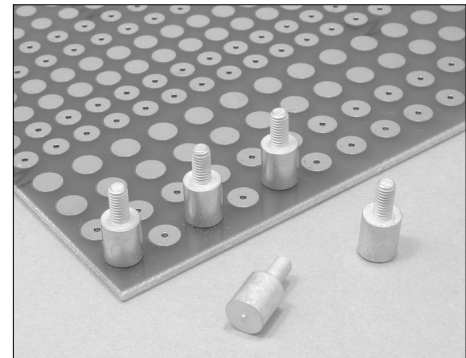
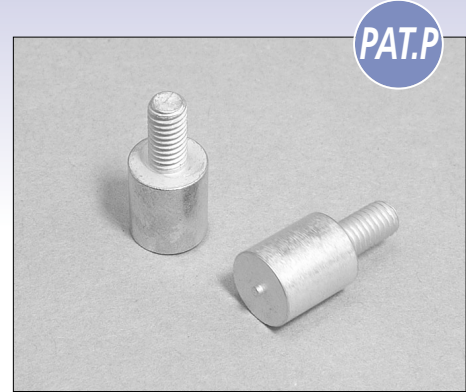
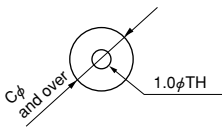

N/O	L	A	B	M	Package	Tape (mm)			
						Width	Pitch	C	D
4SW-1	1	8	7	M4	100pcs/bulk				
4SW-1-T	1	8	7	M4	300pcs/reel	24	20	9.1	6.1
4SW-2	2	8	7	M4	100pcs/bulk				
4SW-2-T	2	8	7	M4	300pcs/reel	24	20	10.1	6.7
4SW-3	3	8	7	M4	100pcs/bulk				
4SW-4	4	8	7	M4	100pcs/bulk				
4SW-5	5	8	7	M4	100pcs/bulk				
4SW-6	6	8	7	M4	100pcs/bulk				
4SW-7	7	8	7	M4	100pcs/bulk				
4SW-8	8	8	7	M4	100pcs/bulk				
4SW-9	9	8	7	M4	100pcs/bulk				
4SW-10	10	8	7	M4	100pcs/bulk				
3SW-1	1	6	6	M3	100pcs/bulk				
3SW-1-T	1	6	6	M3	600pcs/reel	24	16	8.2	5.5
3SW-2	2	6	6	M3	100pcs/bulk				
3SW-2-T	2	6	6	M3	500pcs/reel	24	16	9.1	6.1
3SW-3	3	6	6	M3	100pcs/bulk				
3SW-4	4	6	6	M3	100pcs/bulk				
3SW-5	5	6	6	M3	100pcs/bulk				
3SW-6	6	6	6	M3	100pcs/bulk				
3SW-7	7	6	6	M3	100pcs/bulk				
3SW-8	8	6	6	M3	100pcs/bulk				
3SW-9	9	6	6	M3	100pcs/bulk				
3SW-10	10	6	6	M3	100pcs/bulk				
2.6SW-1	1	5	6	M2.6	100pcs/bulk				
2.6SW-1-T	1	5	6	M2.6	600pcs/reel	24	16	7.9	5.2
2.6SW-2	2	5	6	M2.6	100pcs/bulk				
2.6SW-3	3	5	6	M2.6	100pcs/bulk				
2.6SW-4	4	5	6	M2.6	100pcs/bulk				
2.6SW-5	5	5	6	M2.6	100pcs/bulk				
2.6SW-6	6	5	6	M2.6	100pcs/bulk				
2.6SW-7	7	5	6	M2.6	100pcs/bulk				
2.6SW-8	8	5	6	M2.6	100pcs/bulk				
2.6SW-9	9	5	6	M2.6	100pcs/bulk				
2.6SW-10	10	5	6	M2.6	100pcs/bulk				
2SW-1	1	4	5	M2	100pcs/bulk				
2SW-1-T	1	4	5	M2	900pcs/reel	16	12	6.8	4.5
2SW-2	2	4	5	M2	100pcs/bulk				
2SW-3	3	4	5	M2	100pcs/bulk				
2SW-4	4	4	5	M2	100pcs/bulk				
2SW-5	5	4	5	M2	100pcs/bulk				
2SW-6	6	4	5	M2	100pcs/bulk				
2SW-7	7	4	5	M2	100pcs/bulk				
2SW-8	8	4	5	M2	100pcs/bulk				
2SW-9	9	4	5	M2	100pcs/bulk				
2SW-10	10	4	5	M2	100pcs/bulk				



No. 1 distributor of MAC8

SHINDENKIZAI Co., LTD.

Contact

e-mail: info@mac8japan.com FAX: +81-3-3253-5965

<http://www.mac8japan.com>