

SPECIFICATION

Current Rating: 1.5 AMP
 Voltage Rating: 250 V AC
 Insulation Resistance: 1000MΩ Min.
 Contact Resistance: 30m Ω Max
 Dielectric Voltage: 750V AC for one minute
 Insertion Force: 35N Max
 Withdrawal Force: 10N Min

MATERIAL

Insulator: Nylon 9T, UL94V-0
 Contact Pin: Phosphor Bronze

ORDER INFORMATION

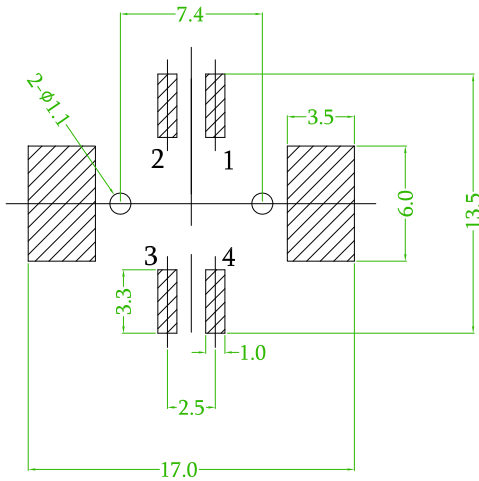
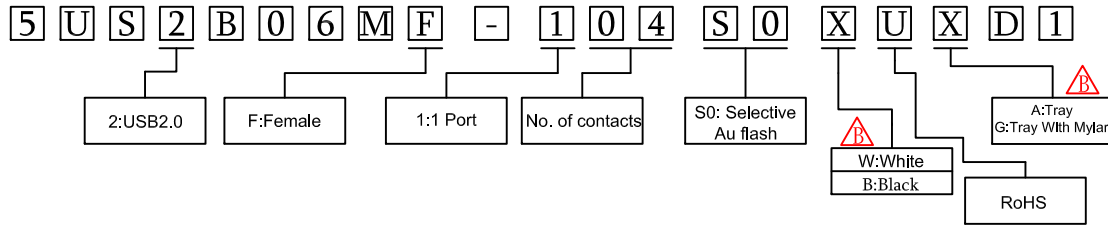

PCB LAYOUT
(COMPONENT SIDE)

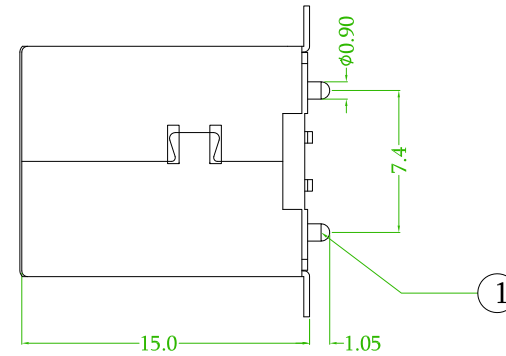
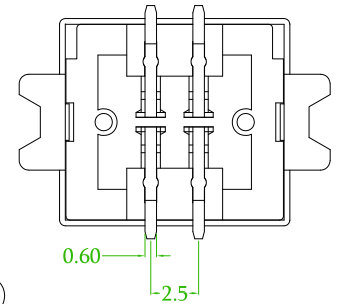
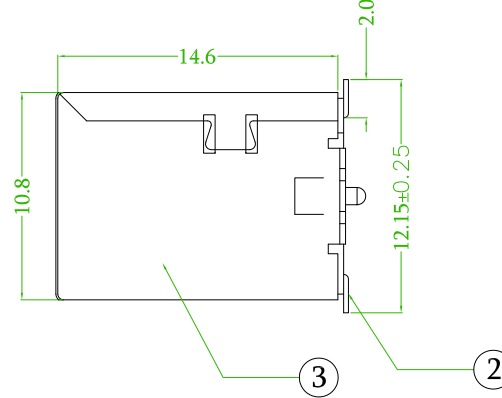
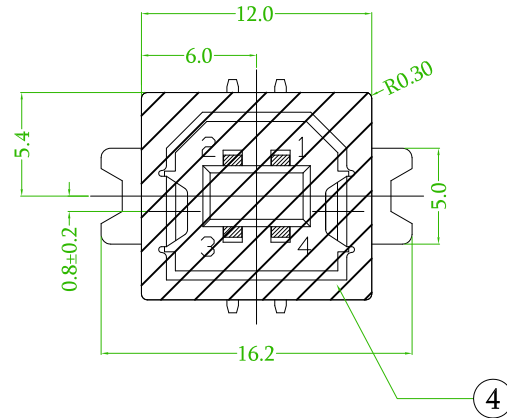

NO.	NAME	MATERIAL	FINISH	REMARK	Q'TY
1	HOUSING	NYLON PA9T G.F.	WHITE/BLACK		1
2	PIN TERM.	PHOS. BRONZE T:0.25	GOLD/TIN PLATED	Gold:1"3u"; Ni:40"60u"; TIN:120u" (100% pure Tin of lead free plating)	4

Old P/N: USB-001KH-BX-U



Langer Acker 32
 30900 Wedemark
 Germany

(+49) 5130 / 58642-0
 info@amec-gmbh.de
 www.amec-gmbh.de

 糧德精密有限公司 Amtek Technology Co., Ltd. TEL: 886-2-2260-6878 FAX: 886-2-2260-8030	品名 TITLE	USB B TYPE FEMAL SMT				頁數 Page	1/1
	品號 PART NO.	5US2B06MF-104S0XUXD1				繪圖 DRAWN	Roy 2016/03/07
	圖號 DRAWING NO.	GW216-JF200	版本 REV.	B	核對 CHECKED	Wanling 2016/03/07	
	客戶品號 CUSTOMER P/N		比例 SCALE	None	承認 APPROVED	John 2016/03/07	
	公差 TOLERANCE	.X ± 0.25 .XX ± 0.13	單位 UNIT	mm	THIRD ANGLE PROJECTION		