

## RECOMMENDED PCB LAYOUT

**amec**

Langer Acker 32  
30900 Wedemark  
Germany

(+49) 5130 / 58642-0  
info@amec-gmbh.de  
www.amec-gmbh.de



糧德精密有限公司  
Amtek Technology Co., Ltd.  
TEL: 886-2-2260-6878  
FAX: 886-2-2260-8030

品名 TITLE	HDMI FEMALE SMT A TYPE				頁數 Page	2/2
品號 PART NO.	5HMCM1F-XXXU-XX			繪圖 DRAWN	Gary 2017/04/14	
圖號 DRAWING NO.	GN127-GA378	版本 REV.	A	核對 CHECKED	Jonny 2017/04/14	
客戶品號 CUSTOMER P/N		比例 SCALE	None	承認 APPROVED	Aaron 2017/04/14	
公差 TOLERANCE	.X ± 0.35 .XX ± 0.25	.X° ± 3	單位 UNIT	mm	THIRD ANGLE PROJECTION	

**SPECIFICATION**

Current Rating: 0.5 AMP  
 Insulation Resistance: 100MΩ Min.  
 Contact Resistance: 30mΩ Max.  
 Dielectric Voltage: 500VAC for one minute  
 Insertion Force: 4.5Kgf  
 Extraction Force: 0.3 Kgf  
 Operation Temperature: -20°C to +80°C

**MATERIAL**

Contact: Copper Alloy  
 Insulator: Hi-Temp. Thermoplastic, UL94V-0  
 Shell: Stainless Steel

**ORDER INFORMATION**

5 H M C M 1 F - X X

C:Female C Type

G0:Gold Flash  
 GF: Au 15u"  
 GD: Au 30u"

X U - X X

H:T/R W/O Mylar  
 M:T/R With Mylar

RoHS

01: A Type  
 02: B Type

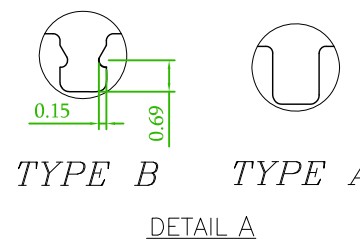
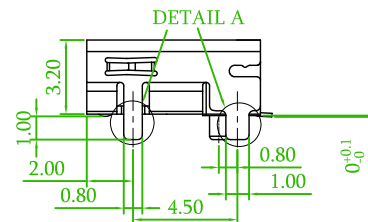
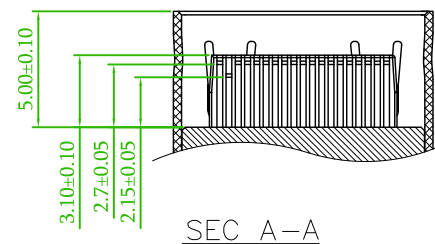
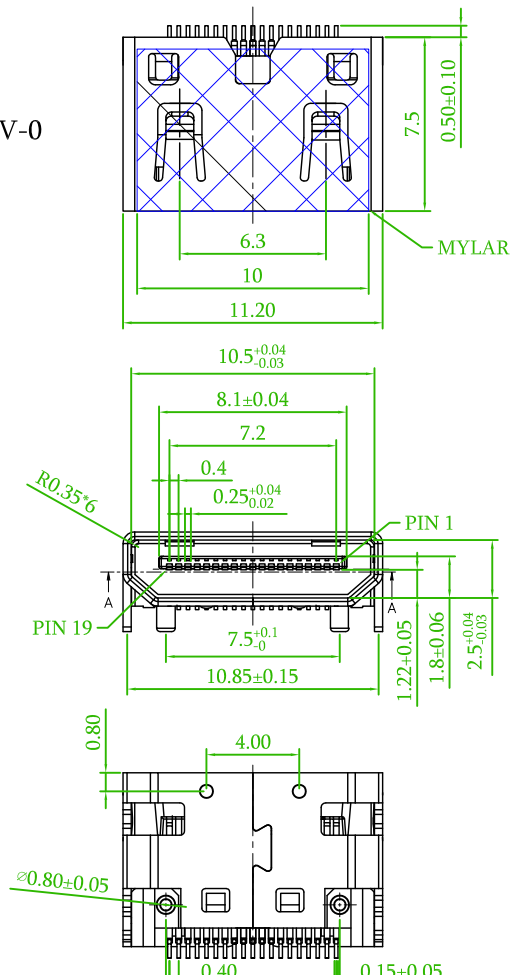

Langer Acker 32  
 30900 Wedemark  
 Germany

(+49) 5130 / 58642-0  
 info@amec-gmbh.de  
 www.amec-gmbh.de

糧德精密有限公司  
 Amtek Technology Co., Ltd.  
 TEL: 886-2-2260-6878  
 FAX: 886-2-2260-8030

品名 TITLE	HDMI FEMALE SMT A TYPE				頁數 Page	1/2
品號 PART NO.	5HMCM1F-XXXU-XX			繪圖 DRAWN	Gary 2017/04/14	
圖號 DRAWING NO.	GN127-GA378	版本 REV.	A	核對 CHECKED	Jonny 2017/04/14	
客戶品號 CUSTOMER P/N		比例 SCALE	None	承認 APPROVED	Aaron 2017/04/14	
公差 TOLERANCE	.X ± 0.35 .XX ± 0.25	.X°±3	單位 UNIT	mm	THIRD ANGLE PROJECTION	