

PROPOSAL

REV	ECN No.	DATE	REMARK
A.4	EK2015-0232-03	20151119	ACTIVE

NOTES:

- MATERIAL:
SIDE/CENTER I/M:THERMOPLASTIC (LCP) UL 94V-0,COLOR:BLACK
CONTACT:COPPER ALLOY.
SHELL: STAINLESS STEEL.
MID-PLATED: STAINLESS STEEL.
- PALTEING:
TERMINAL:GOLD PLATED ON THE CONTACT AREA (SEE TABLE 2).
BRIGHT TIN 30 MICROINCH MIN. ON THE SOLDER TAIL AREA.
NICKEL 80 MICROINCH MIN. UNDERPLATED OVER ALL.
MID-PLATE:CLEAN.
SHELL: SOLDERABILITY NICKEL 80 MICROINCH MIN. PLATED OVER ALL.
- CONNECTOR INSERTION FORCE: 5~20N AT A MAXIMUM RATE OF 12.5MM PER MINUTE.
- CONNECTOR EXTRACTION FORCE: 8~20N UP TO 1000 MATING CYCLES,AND 6~20N AFTER SPECIFIED INSERTION/EXTRACTION OR DURABILITY CYCLES AT MAXIMUM RATE OF 12.5MM PER MINUTE.
- DURABILITY:10000 CYCLES.
- SALT SPRAY 48 HOURS.
- PACKAGE SPECIFICATION:PK-80239-001
- PRODUCT SPECIFICATION:PS-80239-001

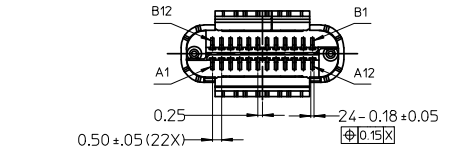
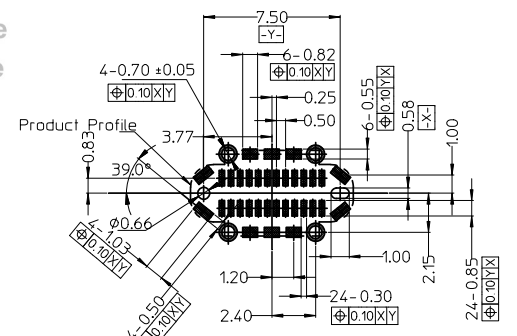
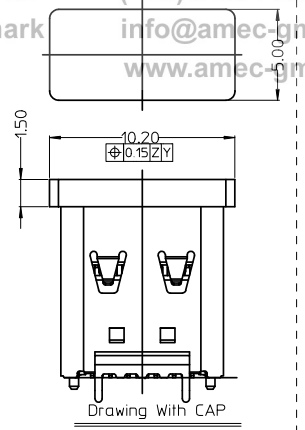
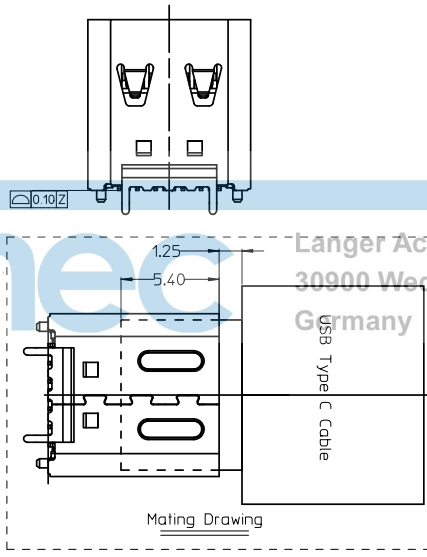
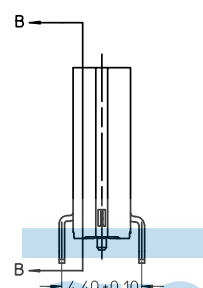
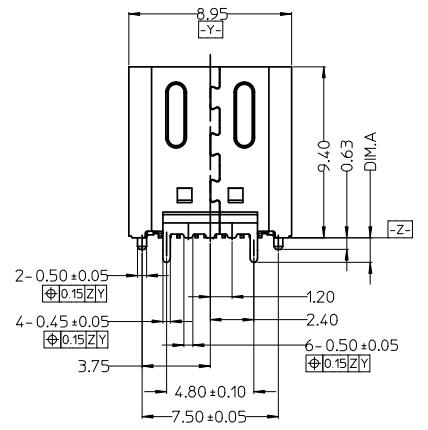
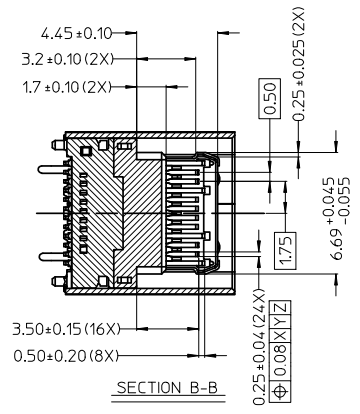
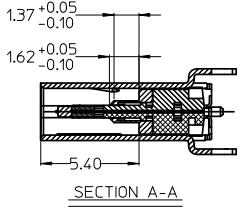
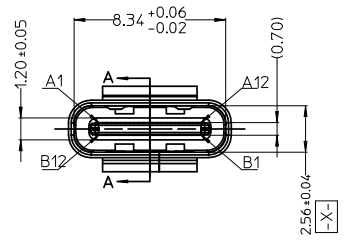

TABLE 1: PIN ASSIGNMENT:

Pin No.	Signal Name	Pin No.	Signal Name
A1	GND	B12	GND
A2	TX1+	B11	RX1+
A3	TX1-	B10	RX1-
A4	VBUS	B9	VBUS
A5	CC1	B8	SBU2
A6	D+	B7	D-
A7	D-	B6	D+
A8	SBU1	B5	CC2
A9	VBUS	B4	VBUS
A10	RX2-	B3	TX2-
A11	RX2+	B2	TX2+
A12	GND	B1	GND

TABLE 2:

PART NO.	DIM.A	PLATING SPEC ON CONTACT AREA
80239-1021	1.35mm	GOLD FLASH ON THE CONTACT AREA
80239-2021	1.80mm	GOLD FLASH ON THE CONTACT AREA

ROHS COMPLIANT LEAD&HALOGEN FREE

MATERIAL NO.: 80239 SERIES

REVIEW TABLE FOR DETAILS

QUALITY SYMBOL	TOLERANCE
$\nabla = 0$	GENERAL TOLERANCES (UNLESS SPECIFIED)
∇	x.xxxx ± ---
∇	x.xxx ± ---
∇	x.xx ± 0.20
∇	x.x ± 0.25
∇	ANGULAR ± --°

THIS DRAWING CONTAINS INFORMATION THAT IS PROPRIETARY TO Bellwether Electronic Corp. AND SHOULD NOT BE USED WITHOUT WRITTEN PERMISSION

TITLE: USB TYPE C CONNECTOR 0.50MM PITCH, 24 CIRCUITS VERTICAL TYPE

ECN DESCRIPTION: PROPOSAL(MODIFY SOLDER TAIL LENGTH)

DRAWN BY: Eric Bai DATE: 20151119

CHECKED BY: Jerry Wang DATE: 20151119

APPROVED BY: Larry Chen DATE: 20151119

DOCUMENT NO.: SD-80239-001

SHEET NO.: 1 OF 1

DIMENSION STYLE: MM ONLY

DESIGN UNITS: METRIC

SCALE: 1:1

THIRD ANGLE PROJECTION

frame size: A4 QR-QP025-06 REV.:A

REV	ECN No.	DATE	REMARK

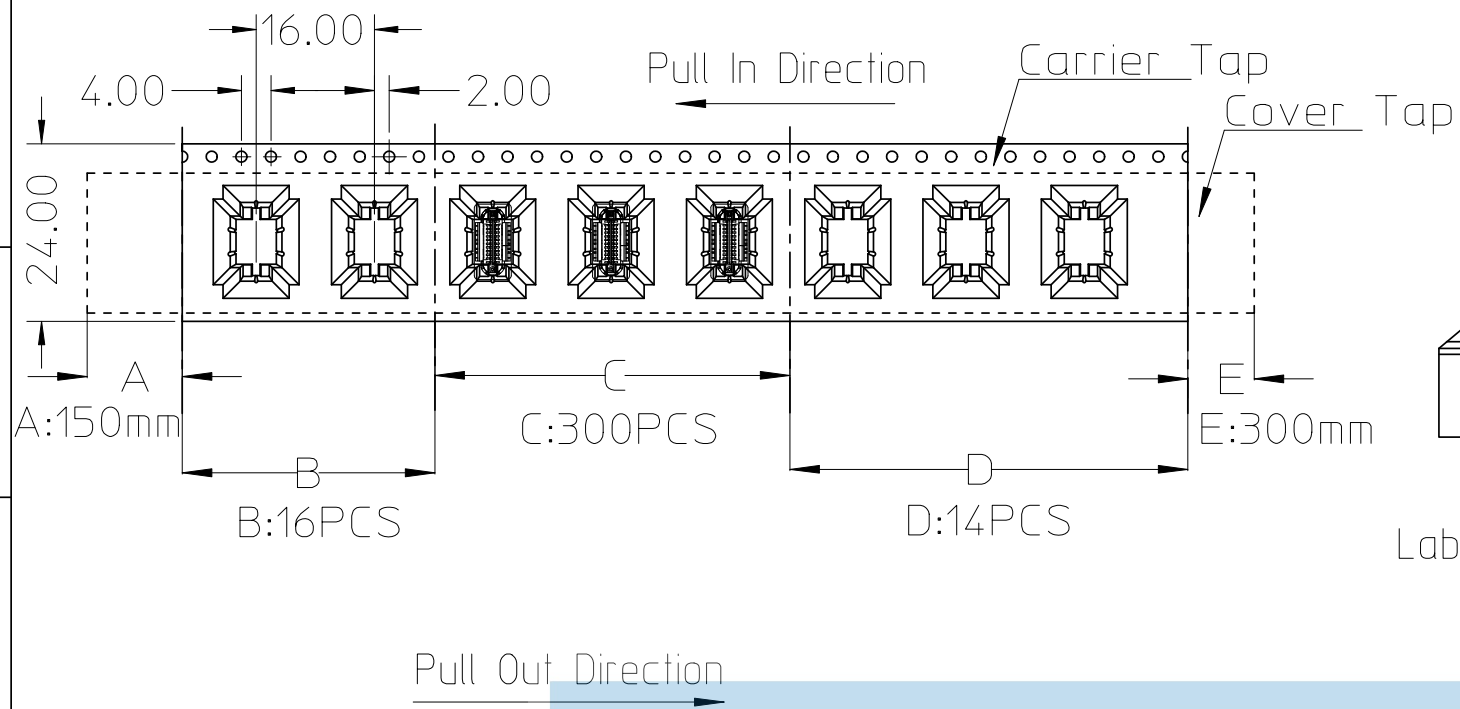

Carton: 360x360x195

7 Reels

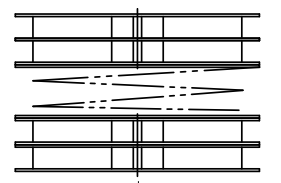
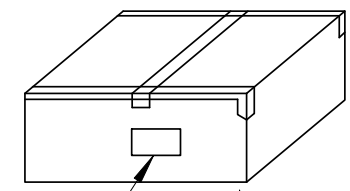

Lable

PE Bag

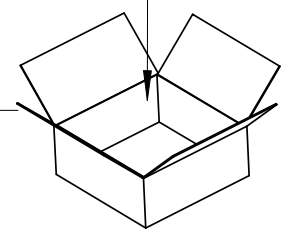
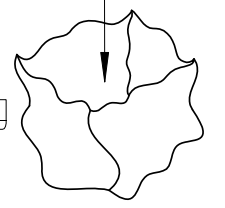

Pull Out Direction

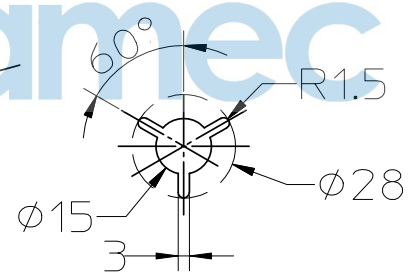
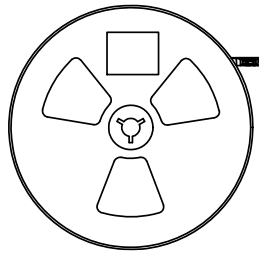
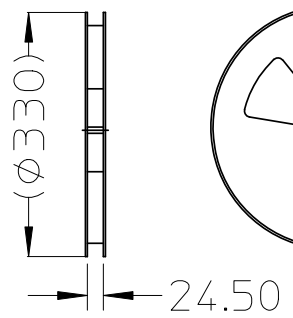

Langer Acker 32 (+49) 5130 / 58642-0
 COFFERS: Wedemark info@amec-gmbh.de
 MATERIAL: PS, THICKNESS: 0.50±0.05mm, COLOUR: BLACK

- 2.STAPLES SHOULD BE ONLY USED TO SET UP CARTON.ALL CARTONS CLOSURE MUST BE DONE WITH TAPE.
- 3.FILL PACKAGING TAPE REEL WITHE THE QUANTITIES AS INDICATED IN THE CHART.

CONN. PART NO.	CONN. QTY./REEL	REEL QTY./CARTON	CONN. QTY./CARTON
80239-1021	300	7	2100 PCS

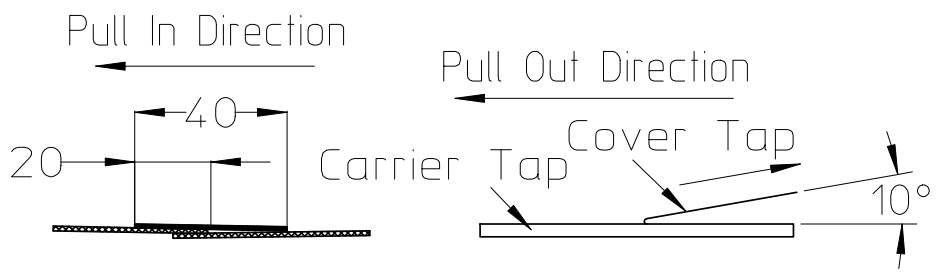

ROHS COMPLIANT LEAD&HALOGEN FREE

MATERIAL NO.:
80239-1021

REVIEW TABLE FOR DETAILS

GENERAL TOLERANCES (UNLESS SPECIFIED)	
x.xxxxx	± ---
x.xxx	± ---
x.xx	± 0.20
x.x	± 0.25
ANGULAR	± --°

THIS DRAWING CONTAINS INFORMATION THAT IS PROPRIETARY TO Bellwether Electronic Corp. AND SHOULD NOT BE USED WITHOUT WRITTEN PERMISSION

TITLE	USB TYPE C CONNECTOR 0.50MM PITCH, 24 CIRCUITS VERTICAL TYPE		ECN DESCRIPTION	PROPOSAL
DRAWN BY	Eric Bai	DATE	20150918	
CHECKED BY	Jerry Wang	DATE	20150918	
APPROVED BY	Larry Chen	DATE	20150918	
DOCUMENT NO.	PK-80239-001	SHEET NO.	1 OF 1	
DIMENSION STYLE	MM ONLY	DESIGN UNITS	METRIC	SCALE
				1:1
				THIRD ANGLE PROJECTION

PRODUCT DESCRIPTION:

USB TYPE C Connector

PRODUCT NUMBER:

80239/80243/80245 series



<u>REVISION</u> A	<u>ECR/ECN</u> EK2015-0***	<u>DOCUMENT NUMBER</u> PS-80239-001	<u>SHEET</u> 1 of 8
<u>DATE:</u> 2015/08/03	<u>CREATED / REVISED</u> Eric Bai	<u>CHECKED BY:</u> Jerry Wang	<u>APPROVED BY:</u> Larry Chen

1.0 SCOPE.....2

2.0 APPLICABLE DOCUMENTS.....2

3.0 REQUIREMENT3~8



Langer Acker 32
30900 Wedemark
Germany

(+49) 5130 / 58642-0
info@amec-gmbh.de
www.amec-gmbh.de

<u>REVISION</u> A	<u>ECR/ECN</u> EK2015-0***	<u>DOCUMENT NUMBER</u> PS-80239-001		<u>SHEET</u> 2 of 8
<u>DATE:</u> 2015/08/03		<u>CREATED / REVISED</u> Eric Bai	<u>CHECKED BY:</u> Jerry Wang	<u>APPROVED BY:</u> Larry Chen

1.SCOPE:

1.1 Content

This product specification defines the product performance and the test methods to ascertain the performance of the **USB TYPE C Connector** which is designed and manufactured by Bellwether Electronic Corp.

1.2 Qualification

Tests and inspection shall be performed in accordance with the requirements, tests and methods contained herein. All the inspections shall be conducted by using plan for the product drawings and the inspection these products. A re-qualification test shall be conducted immediately following all major process changes.

2. REFERENCED DOCUMENTS

EIA-364-1000.01

EIA-364

IEC-801-2

USB TYPE C Specification Rev:1.1

In case of any contradiction between this document and referenced documents, this document will take precedence.

3. REQUIREMENT

3.1 Design

The product shall be as specified by Bellwether's customer drawing .

3.2 Material and Finish

See Bellwether's customer drawing .

3.3 Electrical & Mechanical Requirements

See Bellwether's Product Specification .

3.4 Application Performance:

3.4.1 Operating Environment: -55°C to +85°C, 85%RH, without loss of function.

3.4.2 Storage Environment: -40°C to +60°C, 85%RH, without loss of function at operating temperatures.

3.4.3 This connector is designed for reflow processing and must meet the specified requirements accordingly.

3.5 High Frequency Performance:

Refer to the USB TYPE C Specification 1.1.

3.6 Health, Safety and Environment

Hazardous substances (Environment related to be controlled substances) contained in this product should comply with the regulations specified by RoHS. The concentrations of Br&Cl can satisfy the requirement of Halogen-Free in RoHS for Halogen-Free product.

3.7 Packaging and Transportation

3.7.1 Hazardous substances (Environment related to be controlled substances) contained in packaging materials should comply with the regulations specified by RoHS.



Langer Acker 32
30900 Wedemark
Germany

(+49) 5130 / 58642-0
info@amec-gmbh.de
www.amec-gmbh.de

<u>REVISI</u> A	<u>ECR/ECN</u> EK2015-0***	<u>DOCUMENT NUMBER</u> PS-80239-001		<u>SHEET</u> 3 of 8
<u>DATE:</u> 2015/08/03		<u>CREATED / REVISED</u> Eric Bai	<u>CHECKED BY:</u> Jerry Wang	<u>APPROVED BY:</u> Larry Chen

3.7.2 Packaging carton with products should be subject to falling test.

3.7.3 Other requirements see Bellwether's packaging specification .

3.8 Test Description

The product is designed to meet the requirements specified in section 3.9. Unless otherwise specified, all tests and measurements are to be performed at the following conditions:

Temperature: 15°C to 35°C.

Relative Humidity: 25% to 85%.

Atmospheric pressure : 86kPa to 106 kPa.

3.9. Test Requirements and Methods

3.9.1 Appearance		
Items	Test Methods	Requirements
Appearance	Comply with method EIA 364-18. Visual inspection in compliance with applicable specification and document are performed. The test samples shall be free from defects such as damage, creep, deformation, blister and burrs that are detrimental to the function and appearance of test samples.	Connector & contact shall have no evidence of physical defects or otherwise unfit for testing.
Electrical Performance :		
3.9.2 Low Level Contact Resistance	Comply with method EIA 364-23. Open circuit voltage is 20mV maximum and test current is 100mA. Measurement to use Kelvin 4-wire method.	Initial:40 mΩ maximum initial for the Power (VBUS) and Ground (GND) contacts and all other contacts . After test:Change from initial value:10 mΩ maximum .
3.9.3 Dielectric Withstanding Voltage	Comply with method EIA 364-20. The dielectric must withstand 100 VAC (RMS) for one minute at sea level between adjacent contacts of unmated and mated connectors.	No Breakdown.
3.9.4 Insulation Resistance	Comply with method EIA 364-21. Mated connector with a voltage of 100V DC for two minutes maximum, or until stabilized between adjacent terminals.	100 MΩ minimum.
3.9.5 Contact Current Rating	Comply with method EIA 364-70 Method 2. A current of 5.0 A shall be applied collectively to Vbus pin(i.e., pins A4,A9,B4.B9) and 1.25 A applied to the VCONN pin(i.e.,B5 of the plug connector) with the return path through the corresponding GND pin(i.e., pin A1,A12,B1, and B12). Additionally, a minimum current of 0.25 A shall be applied individually to all the other contacts.	When the current is applied to the contacts, the temperature rise shall not exceed 30°C at any point on the USB Type C mated plug and Connector under test, when measured at an ambient temperature of 25°C
Mechanical Performance :		
3.9.6 Insertion Force	Comply with method EIA 364-13. The mating force is the peak force measured while the plug and Connector sample are mated normally. Mating speed: 12.5 mm per minute maximum.	The initial connector insetion force shall be within the range from 5 N to 20N .
3.9.7 Extraction Force	Comply with method EIA 364-13. The unmating force is the peak force measured while the plug and Connector sample separated from the mated position. Un-mating speed: 12.5 mm per minute maximum.	The connector extraction force shall be within the range of 8 N to 20 N up to 1,000 mating cycles and within the range of 6 N to 20 N after the specified insertion/extraction or durability cycles

<u>REVISION</u> A	<u>ECR/ECN</u> EK2015-0***	<u>DOCUMENT NUMBER</u> PS-80239-001	<u>SHEET</u> 4 of 8
<u>DATE:</u> 2015/08/03	<u>CREATED / REVISED</u> Eric Bai	<u>CHECKED BY:</u> Jerry Wang	<u>APPROVED BY:</u> Larry Chen

3.9.8 Durability	Comply with method EIA 364-09. Test sample are subjected to fully mate and unmate for 10000 cycles. The durability test shall be done at a maximum rate of 200 cycles per hour .	No physical damage to any part of the connector.
3.9.9 Wrenching Strength	The wrenching strength test shall be performed using virgin parts. Perpendicular forces (Fp) are applied to a plug when inserted at a distance (L) of 15mm from the edge of the Connector. These forces shall be applied in all four direction. i.e., left, right, up, and down).	<ul style="list-style-type: none"> No plug and Connector damage shall occur when a force of 0~50 N is applied; #: The plug may be damaged, but only in such a way that the Connector does not sustain damage when a force of 50~75 N is applied ; #: The plug shall be mated with a different Connector after the forces are applied to verify no damage has occurred that causes discontinuity or shorting.
3.9.10 Solder ability	Comply with method EIA 364-52. Soldered at a temperature 255 °C +/-5 °C for an immersion duration of 5 s.	Solder shall cover a minimum of 95% of the surface being immersed.
3.9.11 Vibration	Comply with method EIA-364-28. Vibration randomly from 20 to 500HZ at condition VII, letter D(3.10G's). Test duration for each axis is 15 minute(total 45 minute).	No evidence of physical damages.
Environmental Performance :		
3.9.12 Temperature Life	Comply with method EIA 364-17, Method A. Temperature Life test temperature and duration: 105° C without applied voltage for 120 hours. 105° C without applied voltage for 72 hours when used as preconditioning in EIA 364-1000.01.	After the test, the sample shall pass the requirement of 3.9.1, 3.9.2 specification.
3.9.13 Cycling Temperature and Humidity	Comply with method EIA 364-31. Cycle the connector or socket between 25 °C ± 3 °C at 80 % ± 3% RH and 65 °C ± 3 °C at 50 % ± 3% RH. Ramp times should be 0.5 hour and dwell times should be 1.0 hour. Dwell times start when the temperature and humidity have stabilized within the specified levels. Perform 24 such cycles.	After the test, the sample shall pass the requirement of 3.9.1, 3.9.2 specification.
3.9.14 Thermal Shock	Comply with method EIA 364-32, Test Condition I. 10 cycles of mated connectors. a) -55 °C for 30 minutes b) +85°C for 30 minutes	There shall be no evidence of any physical damage.
3.9.15 Thermal disturbance	Cycle the connector or socket between 15 °C ± 3 °C and 85 °C ±3 °C, as measured on the part. Ramps should be a minimum of 2°C per minute, and dwell times should insure that the contacts reach the temperature extremes (a minimum of 5 minutes). Humidity is not controlled. Perform 10 such cycles.	After the test, the sample shall pass the requirement of 3.9.1, 3.9.2 specification.
3.9.16 Thermal Cycling	Cycle the connector or socket between 15 °C ± 3 °C. and 85 °C ±3 °C, as measured on the part. Ramps should be a minimum of 2 °C per minute, and dwell times should insure that the contacts reach the temperature extremes (a	After the test, the sample shall pass the requirement of 3.9.1, 3.9.2 specification.

<u>REVISION</u> A	<u>ECR/ECN</u> EK2015-0***	<u>DOCUMENT NUMBER</u> PS-80239-001		<u>SHEET</u> 5 of 8
<u>DATE:</u> 2015/08/03		<u>CREATED / REVISED</u> Eric Bai	<u>CHECKED BY:</u> Jerry Wang	<u>APPROVED BY:</u> Larry Chen

	minimum of 5 minutes). Humidity is not controlled. Perform 500 such cycles.	
3.9.17 Mixed Flowing Gas	Comply with method EIA 364-65, Class II A. duration: 7-days, Options #1A and #1B as specified in EIA 364-1000.01.	After the test, the sample shall pass the requirement of 3.9.1, 3.9.2 specification.
High Frequency Characteristics		
3.9.18 Mated Connector Impedance (Differential)	Comply with method EIA 364 -108. This test ensures that the signal conductors of the USB Type C connectors have the proper impedance. Rise time = 40ps (20%-80%) rise time of a differential TDR. (Mated connector includes cable termination areas).	76Ω minimum, 96Ω maximum. (Only for connector Area.) SuperSpeed pairs only.
3.9.19 Differential Insertion Loss of Super Speed Pairs of Mated Cable Assembly	Comply with method EIA-360-101. The differential insertion loss measures the differential signal energy transmitted through the mated connector.	The differential insertion loss curve must be above or on the curve defined by the following vertices: (100 MHz, -0.25 dB), (2.5 GHz, -0.35 dB), (5 GHz, -0.45 dB), (10 GHz, -0.75 dB) and (15 GHz, -1.85 dB), See Figure 3-1.
3.9.20 Differential Return Loss of Super Speed Pairs of Mated Cable Assembly	Comply with method EIA-360-101. The differential return loss measures the differential signal energy transmitted through the mated connector.	The differential insertion loss curve must be above or on the curve defined by the following vertices: (100 MHz, -20 dB), (5 GHz, -20 dB), (10 GHz, -13 dB) and (15 GHz, -6 dB), See Figure 3-2.
3.9.21 Differential Near-End and Far-End Crosstalk between Super Speed Pairs of Mated Cable Assembly	Comply with method EIA-360-90. The differential crosstalk measures the unwanted coupling between differential pairs.	Both near-end crosstalk and far-end crosstalk for mated connector pairs are specified. The recommended limit is defined by the follow vertices: (100 MHz, -40 dB), (5 GHz, -40 dB), (10 GHz, -36 dB) and (15 GHz, -30 dB), See Figure 3-3.
3.9.22 Differential Crosstalks between Super Speed Pairs and D+/D- pair of Mated Cable Assembly	Comply with method EIA-360-90. The differential near-end and far-end crosstalk between the D+/D- pair and the Super Speed pairs in mated connector should be managed not to exceed the limit.	The recommended limit is defined by the follow vertices: (100 MHz, -40 dB), (5 GHz, -40 dB), and (7.5 GHz, -36 dB), See Figure 3-4.

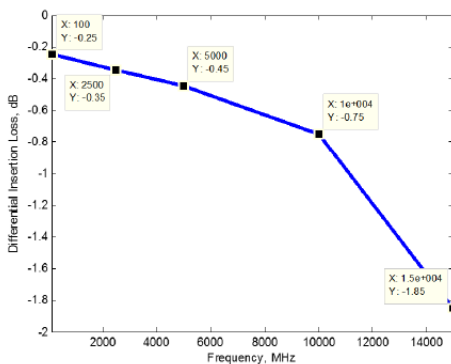

Figure 3-1. Differential insertion loss requirement

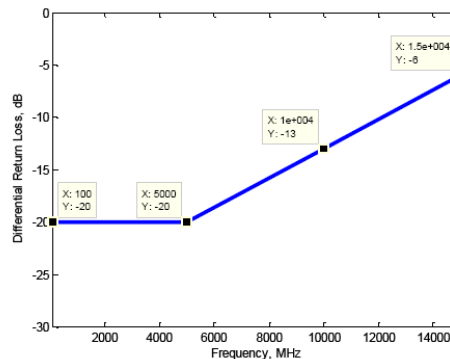

Figure 3-2. Differential return loss requirement

<u>REVISION</u> A	<u>ECR/ECN</u> EK2015-0***	<u>DOCUMENT NUMBER</u> PS-80239-001	<u>SHEET</u> 6 of 8
<u>DATE:</u> 2015/08/03	<u>CREATED / REVISED</u> Eric Bai	<u>CHECKED BY:</u> Jerry Wang	<u>APPROVED BY:</u> Larry Chen

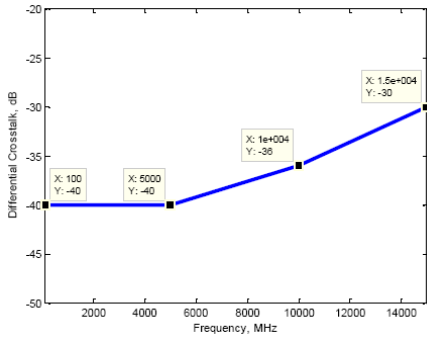

Figure 3-3. Differential Crosstalk between SuperSpeed Pairs

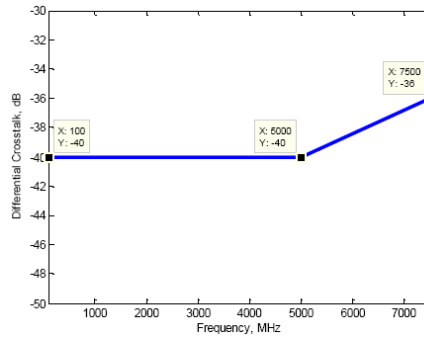

Figure 3-4. Differential Crosstalk between SuperSpeed and D+/D- pair

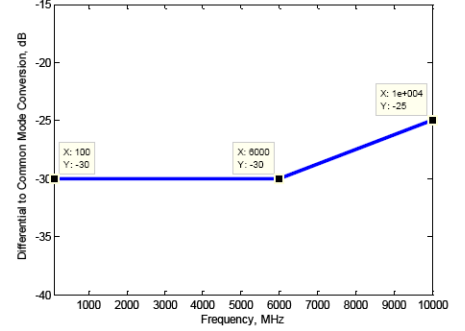

Figure 3-5. Differential to Common Mode Conversion



Langer Acker 32
30900 Wedemark
Germany

(+49) 5130 / 58642-0
info@amec-gmbh.de
www.amec-gmbh.de

<u>REVISION</u> A	<u>ECR/ECN</u> EK2015-0***	<u>DOCUMENT NUMBER</u> PS-80239-001	<u>SHEET</u> 7 of 8
<u>DATE:</u> 2015/08/03	<u>CREATED / REVISED</u> Eric Bai	<u>CHECKED BY:</u> Jerry Wang	<u>APPROVED BY:</u> Larry Chen

Test Sequence

GROUP TEST DESCRIPTION	A	B	C	D	E	F	G	H	I
1 Visual Examination	1,4	1,3	1	1	1	1	1	1	1,10
2 Low Level Contact Resistance				2,5,7	2,5,7,9	2,5,7	2,5,7,9,11	2,5,7,9	3,8
3 Dielectric Withstanding									2,9
4 Insulation Resistance									
5 Contact Current Rating	2								
6 Insertion Force									4
7 Extraction Force									5,7
8 Durability				3(50Cycles manually), 6(3Cycles manually)	3(50Cycles manually), 8(3Cycles manually)	3 (50Cycles manually)	3 (50Cycles manually), 10 (3Cycles manually)	3 (50Cycles manually), 8 (3Cycles manually)	6
9 Wrenching Strength	3								
10 Solderability		2							
11 Vibration						6			
12 Temperature Life				4		4	4(preconditioning)	4(preconditioning)	
3 Cycling Temperature and Humidity					6				
14 Thermal Shock					4				
15 Thermal disturbance					Langer Acker 32 30900 Wedemark Germany	(+49) 51308 58642-0 info@amec-gmbh.de www.amec-gmbh.de			
16 Thermal cycling								6	
17 Mixed Flowing Gas							6		
18 Mated Connector Impedance (Differential)			2						
19 Differential Insertion Loss of Super Speed Pairs of Mated Cable Assembly			3						
20 Differential Return Loss of Super Speed Pairs of Mated Cable Assembly			4						
21 Differential Near-End and Far-End Crosstalk between Super Speed Pairs of Mated Cable Assembly			6						
22 Differential Crosstalks between Super Speed Pairs and D+/D- pair of Mated Cable Assembly			7						
23 Differential to Common Mode Conversion			5						
Sample Size	5	5	3	5	5	5	5	5	5

 Langer Acker 32 (+49) 51308 58642-0
 30900 Wedemark info@amec-gmbh.de
 Germany www.amec-gmbh.de

<u>REVISION</u> A	<u>ECR/ECN</u> EK2015-0***	<u>DOCUMENT NUMBER</u> PS-80239-001		<u>SHEET</u> 8 of 8
<u>DATE:</u> 2015/08/03		<u>CREATED / REVISED</u> Eric Bai	<u>CHECKED BY:</u> Jerry Wang	<u>APPROVED BY:</u> Larry Chen